

BUILDING PRIMITIVE SNARES, TRAPS & DEADLY PUNJI

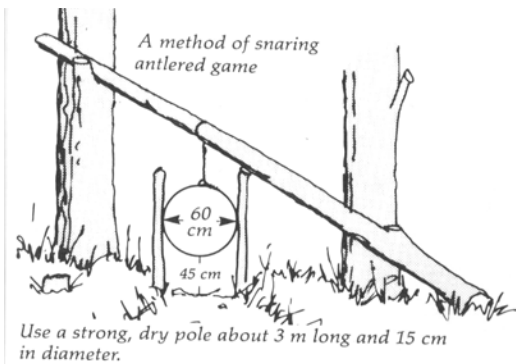

Punji Trap

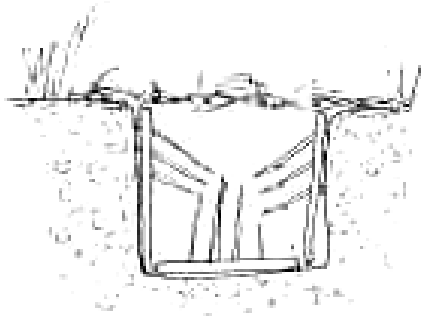

Contents

DESCLAMER 1-2

Introduction 3-4

- 1. Effective WAYS To Set Up Traps. 5-8**
- 2. Tools & Construction of Traps. 9-11**
- 3. Small , Simple Snares Traps. 12-13**
- 4. Spring & Trigger Traps. 14-31**
- 5. SKINING A RABBIT. 32-34**
- 6. Fishing . Building Hooks & Spears. 35-37**
- 7. Alarm Traps. 38-40**
- 8. Deadly PUNJI. 41-60**
- 9. Fire With Friction. 61-66**
- 10. Making Primitive TOOLS. 67-77**
- 11. KNOTS 78-99**

Disclaimer;

Hola, You Can Address me as Spaniard,. I have been through many Year's, highly trained in Many Fields. & Still Learning & Up-Grading. GM Level V. That's 2 Riffs Crossed With A KINGS CROWN, LOL,. I believe that knowledge is an awful thing to waist. So I assembled this book For YOU. One Of many! Yet To Come.

The GOOD STUFF,!

Traps that have decimated Platoons of S.F. & AIRBORNE,. Ask Korean, Or Nam Vets ,! And Present Forces.

The Traps For Survival & PUNJI. Are presented for information purposes only, they are DANGEROUS, some Extremely DEADLY.

Don't use them except in a Survival Situation, Or In Combat. any responsibility for you getting your wrists smacked, Slice Open, Dismembered or anything else, That might Happen. And IT WILL, If Not Careful.

It's YOUR responsibility! Treat These TRAPS, Like You Would A Loaded Rifle,! WITH NO SAFTY. Or A LIVE MINE In YOUR HAND`s.

And Always Work And Approach A TRAP From It's Back SIDE, Swing.

NOTE: The survivor's own preservation must take precedence over humanitarian principles and unfortunately some of the easiest traps can cause considerable suffering to the animal. Regular checking is essential as leaving traps unchecked can prolong an animal's pain and increase the risk that your catch may be taken by an animal predator or that the prey will have managed painfully to struggle free.

Introduction;

Traps and Snares

In all survival situations, the First thing you should never do, Is Panic. Think of your Main Objective, Is Staying Alive, Stay focused & Positive Thinking.

Never Assume, Or Rush. Go Slow And Sure.

Remember There are Bears or wolfs, Packs! Coyotes, Cougars, Bob cats. +++ That will See you as FOOD,!



Food is not Essential, You can live only a few days without WATER, but you can live for weeks without Food. The energy used to find and hunt for food can also burn more calories than they give back. But, if you have plenty of water, & are not sick or injured, and your camp is set up, you can spend some time looking for food. There are many edible plants, but many are also poisonous. You need to know you can Identify edible plants before Eating any of them. Streams my provide fish or crayfish. You can use worms, grubs or insects as bait, or Eat them if needed. Great source Of Protein.

This Book is about Snares and Traps, And Punji. they require some PRACTIC, & Expertise, To develop YOUR skills , In using Them successfully.

With most small game it is easier to trap! Than, to stalk and kill. In a Survival situation setting traps also leaves you with time to attend to other duties like foraging or shelter building.

The title of this page represents the principals of trapping; your trap must Tangle, Dangle, and Strangle or Mangle your Prey.

Putting up several traps around your shelter/retreat gives you more than one opportunity at a time to catch a meal, check all traps regularly to prevent escape and undue suffering. Starting a routine of regularly doing.

The rounds of your traps will provide you with a positive activity, however BE PATIENT, you will need to study the habits of animals to site traps effectively more intelligent creatures will initially be wary of anything new but will quickly come to accept the presence of traps.....That's when they walk into them!

To be effective with any type of trap or snare, you MUST ?????

- 1) Know What you intend to catch.
- 2) Note; Be familiar with the species of animal, Your Trapping. To Be capable of constructing a proper trap.
- 3) Do NOT ALARM; prey by leaving signs of your presence.

There are no catch-all traps you can set for all animals. You must determine what species are in a given area and set your traps specifically with those animals in mind. Look for the following:

- 1) Runs and trails.
- 2) Tracks.
- 3) Droppings.
- 4) Chewed or rubbed vegetation.
- 5) Nesting or roosting sites.
- 6) Feeding and watering areas.

Position your traps and snares where there is proof that animals pass through. You must determine if it is a "RUN" or a "TRAIL." A trail will show signs of use by several species and will be rather distinct. A run is usually smaller and less distinct and will only contain signs of one species.

You may construct a perfect snare, but it will not catch anything if haphazardly placed in the woods. Animals have bedding areas, waterholes, and feeding areas with trails leading from one to another. You must place snares and traps around these areas to be effective.

Use the fluid from the gall and urine bladders of previous kills. Do not use Human urine. Mud, particularly from an area with plenty of rotting vegetation, is also good. Use it to coat your hands when handling the trap and to coat the trap when setting it. In nearly all parts of the world, animals know the smell of burned vegetation and smoke. It is only when a fire is actually burning that they become alarmed. Therefore, smoking the trap parts is an effective means to mask your scent. If one of the above Techniques Are not practical, and if time permits, allow a trap to weather for a few days and then set it. Do not handle a trap while it is weathering.

I Just take Mud mix with grass and leaves, And rub all wood and even the rope,! Works great.

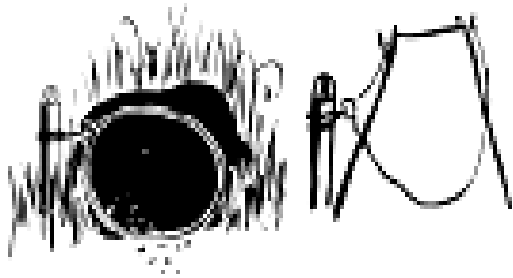

When you position the trap, camouflage it as naturally as possible to prevent detection by the enemy and to avoid alarming the prey.

Traps or snares placed on a trail or run should use the Funnelling System. To build a channel, construct a funnel-shaped barrier extending from the sides of the trail toward the trap, with the narrowest part nearest the trap. Canalization should be inconspicuous to avoid alerting the prey. As the animal gets to the trap, it cannot turn left or right and continues into the trap. Few wild animals will back up, preferring to face the direction of travel. Canalization does not have to be an impassable barrier.

Simple snare trap in front of A Rabbit Barea.

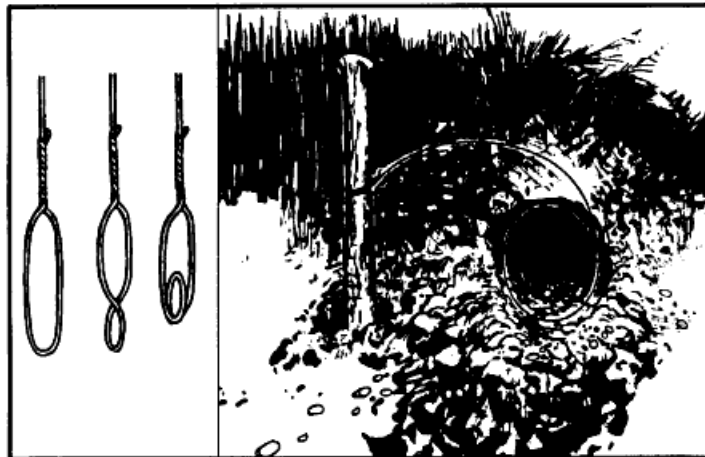

Figure 8-5. Simple snare.

You only have to make it inconvenient for the animal to go over or through the barrier. For best effect, the canalization should reduce the trail's width to just slightly wider than the targeted animal's body. Maintain this constriction at least as far back from the trap as the animal's body length, then begin the widening toward the mouth of the funnel.



Trap and Snare Construction

TOOLS NEED: A KNIFE, Or Silex = FLINT

**Dental Floss, Unseated. Fishing LINE, 10lbs T + .
Paracord. Or WIRE.**

**This Are Also Great, For Building Shelters! &
TOOLS Always Carry DENTAL FLOSS. Or Fishing
Line,.**

A MUST HAVE,,.....

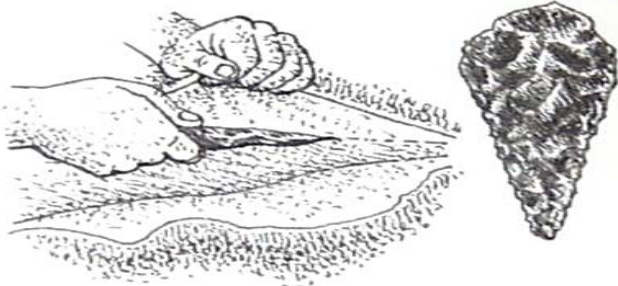

Traps and snares,.....*crush, Slice open, choke, hang, or entangle* the Prey. A single trap or snare will commonly incorporate two or more of these principles. The mechanisms that provide power to the trap are almost always very simple. The struggling victim, the force of gravity, or a bent sapling's tension provides the power.

The simpler traps and snares are made of string or wire. Triggers are made out of available wood. The choice of materials is important. Use strong, springy wood. Do not use dead wood or wood found on the ground. Hide freshly cut ends of wood with mud. Don't tread on the game trail. Do all your preparation off the trail and don't leave any sign that you've been there.

A Snare is a free-running noose that can catch small game around the throat and larger game around the legs. For rabbits and small animals, make a loop a first width in length. Set it four fingers above the ground and one hand's width from an obstruction on the trail. Check that it is securely anchored, with twigs to support the loop in position if necessary.

A wire snare can be supported off the ground on twigs, which can also be used to keep a suspended string noose open.



VERY IMPORTANT: The heart of any trap or snare is the trigger. When planning a trap or snare, ask yourself how it should affect the prey, what is the source of power, and what will be the most efficient trigger. Your answers will help you devise a specific trap for a specific species. Traps are designed to catch and hold or to catch and kill. Snares are traps that incorporate a noose to accomplish either function.



Spring Trigger Trap

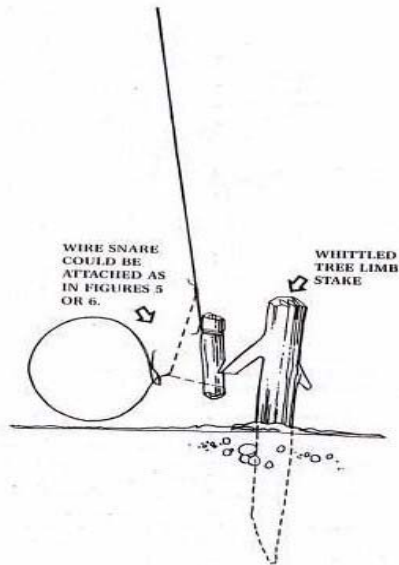

How To Make A Snare

On Rope Or Wire. Put 2 figure 8 loops on each end, Of the snare. A little Smaller Than A dime. One loop will serve as A Connection To the Spring-Pole Mechanism or Stake, & the other will form the lasso Itself.

Now run one loop through the other to form the snare lasso. Draw-Up The loop so that theirs enough room for wire or rope to slide through when put under tension.

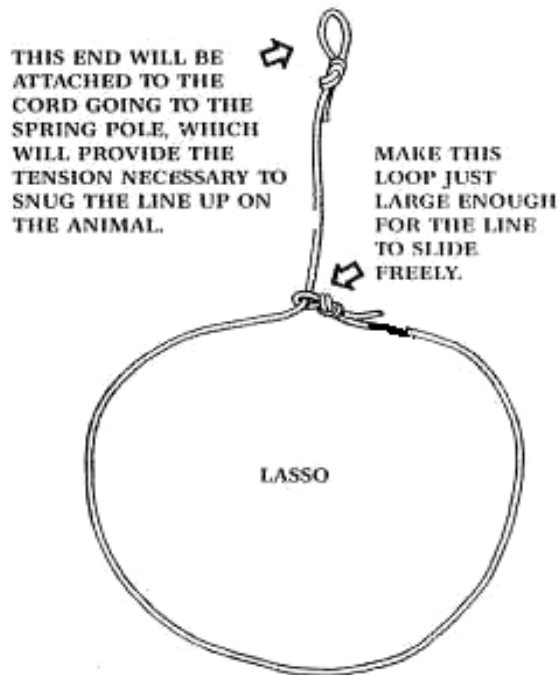

Simple Snare; A simple snare consists of a noose placed over a trail or den hole and attached to a firmly planted stake. If the noose is some type of cordage placed upright on a game trail, use small twigs or blades of grass to hold it up. Filaments from spider webs are excellent for holding nooses open. Make sure the noose is large enough to pass freely over the animal's head. As the animal continues to move, the noose tightens around its neck. The more the animal struggles, the tighter the noose gets. This type of snare usually does not kill the animal. If you use cordage, it may loosen enough to slip off the animal's neck. Wire is therefore the best choice for a simple snare.

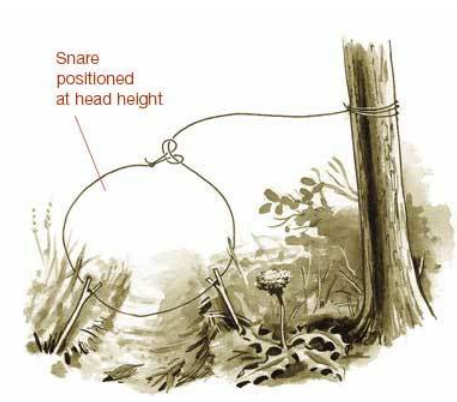

Twitch-Up OR SPRING Snares;

A twitch-up is a supple sapling, which, when bent over and secured with a triggering device, will provide power to a variety of snares. Select a hardwood sapling along the trail. A twitch-up will work much faster and with more force if you remove all the branches and foliage. A simple twitch-up snare uses two forked sticks, each with a long and short leg . Bend the twitch-up and mark the trail below it. Drive the long leg of one forked stick or Peg, firmly into the ground at that point. Ensure the cut on the short leg of this stick is parallel to the ground. Tie the long leg of the remaining forked stick to a piece of cordage secured to the twitch-up. Cut the short leg so that it catches on the short leg of the other forked stick. Extend a noose over the trail. Set the trap by bending the twitch-up and engaging the short legs of the forked sticks. When an animal catches its head in the noose, it pulls the forked sticks apart, allowing the twitch-up to spring up and hang the prey.

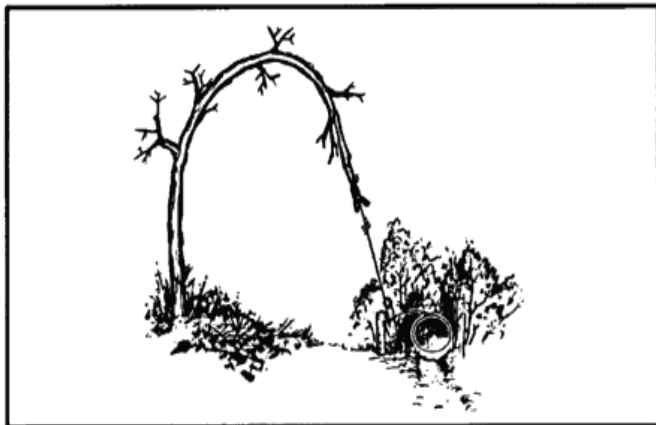
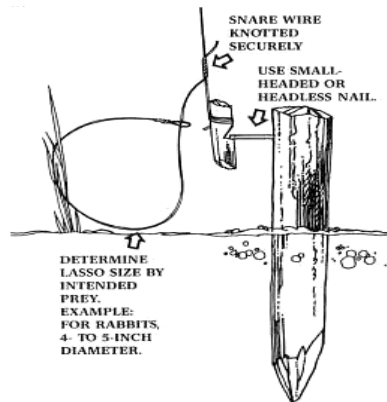
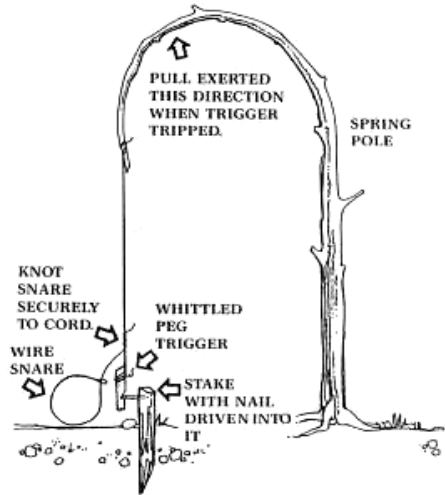
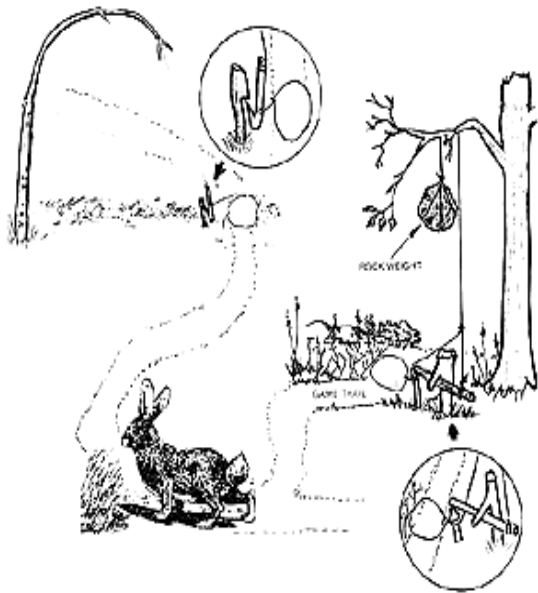

Figure 8-7. Twitch-up snare.

SPRING SNARE: Game running through the snare disengages the trigger bar, and the prey is flung off the ground. Use on game trails or in gaps through rocks or hedges. Cut a notch in trigger-bar . Drive upright into ground. Attach snare to trigger bar, then trigger bar to sapling.

Note: Do not use green sticks for the trigger. The sap that oozes out could glue them together.





Now locate a good springy tree, Hard Wood
 Is preferred as a spring Pole. The spring pole is what
 jerks the line around the animal once the trigger is
 tripped. The small sapling you choose for spring pole will
 have to be springy enough so that when it is bent over, it
 will retain its tendency to POP-UP back up when
 released. This is a very important detail.
 Some small saplings, when bent over, will quickly Lose
 their tendency to POP-UP back UP. YOU Can tell just
 by the feel of the return pull when you bend one over,
 whether it will be satisfactory or NOT.
 If you are undecided on a potential spring pole, bend it
 servile times. If it does not snap back up quickly to an
 upright position, it will not DO.

Finding a Good spring pole will determine the precise location of the Snare.

Remove some or almost all branches, Limbs, leafs. That Are in the way. So Not to interfere with the movement of the spring pole.

Pull down on the cord that you have just attached to the spring pole, to a point where the pole is exerting only enough back pull that you think it would jerk a 4 or 5 lbs off the ground. At this point make sure your cord will reach to with in an inch or so of the ground. Cut any Excess cord.

Next, Whittle a peg from a tree branch to use As a trigger as shown on page 11. You will also need to drive a Stake into the ground with a nail, Or A Wood Drive Trigger.

Next , Tie the snare to the cord, going to the spring pole. And set the Trigger As shown On page 7 Or 11. It should be apparent that any slight tugging on the snare LASSO by an animal trying to get through it, will Bump the peg of , And Release the trigger. Pulling the spring pole back, At Same time tightening the Lasso on the animal.

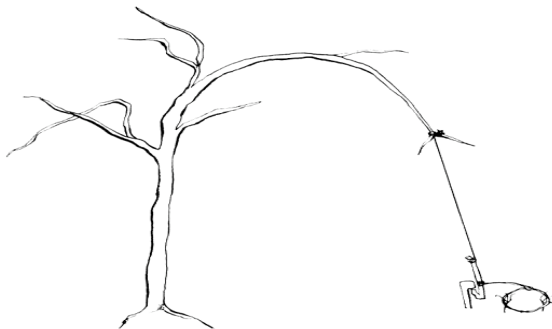

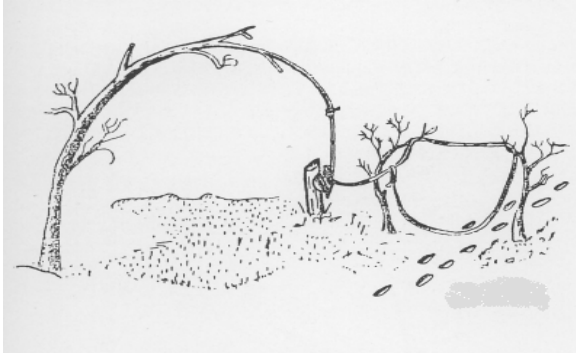

Very Important: If you set the spring pole so that it is exerting too much pull, it will be harder to trip the trigger. A little variance will not matter, but do not set the spring pole overly strong. On VERY WIND DAYS, This Type of Traps can be triggered by the WIND.

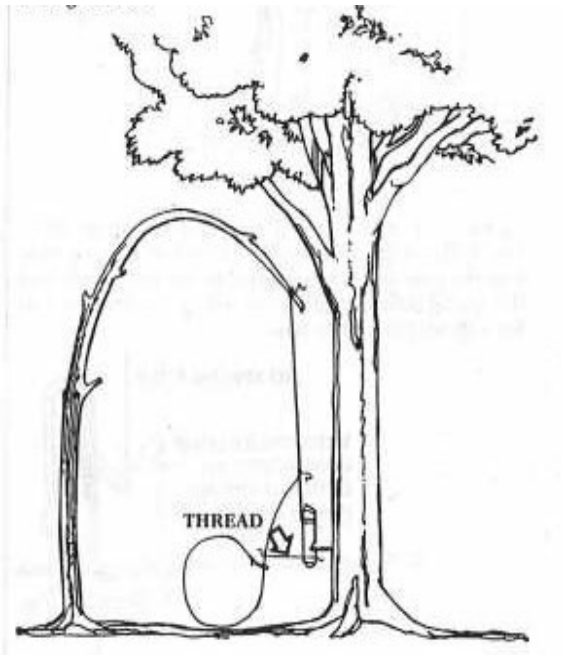

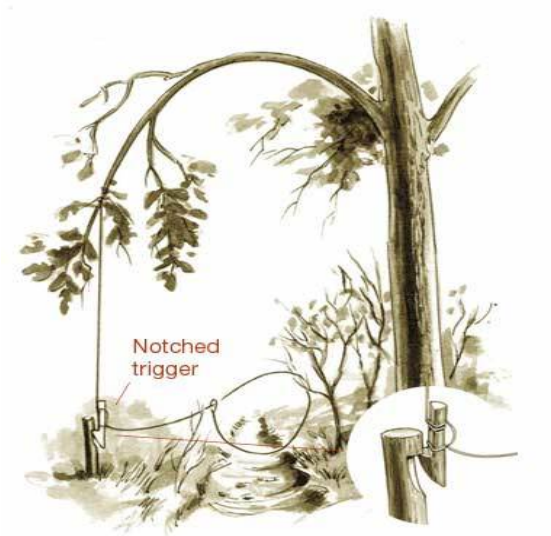

Note; See how Tall grass, bush's, small saplings
 Are used to keep the snare opened, Circular.
 As it's supported & kept of the ground. The key is to set
 the snare at the height of the animals head when he is
 walking. So a rabbit snare-loop or Lasso will be lower to
 the ground, Then A snare made to catch Much LARGER
 PREY.

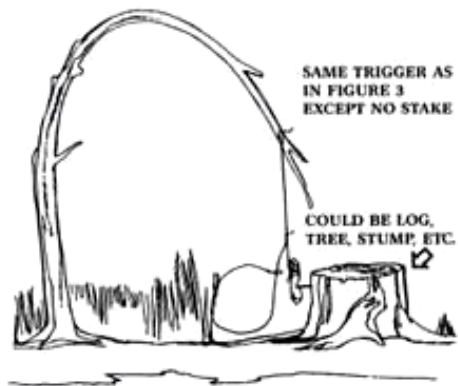

Transplant traps

Transplant traps are just what the Name Say they are: a means of capturing an animal unharmed in order to remove it from your territory or property. Without having to harm or kill the animal.

Such traps are especially handy in a Urban, Environment. In situations where you are trying To get ride of a particular Pest. And trying to avoid explaining To Your neighbour.

How his Prized cat or puddle end up hanging from Your tree, in your yard with a snare wire around It's Neck.

LOL,. Not Good. A transplant Trap will allow you to catch and release the animal unharmed. This is the trap used in the Move Predator.

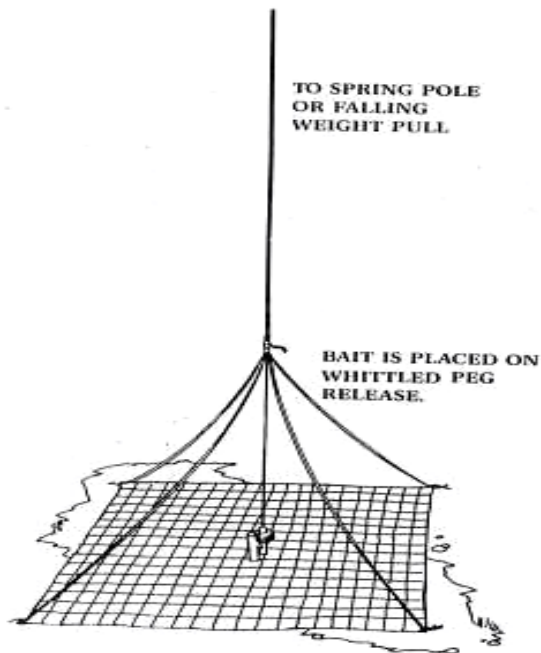

The trap is a simple, snare . Just like the ones in previous pages.

Except that instead of a wire or rope, used as a Lasso or snare Loop from a spring-pole cord, there are 4 cords, Going to the four corners of the Net. { See Picture on page 20 } The net capture is one of the few snare type devices in witch using a falling weight to jerk the net upwards Lifting and capturing the prey works very well, If not better, than using a spring pole.

Note; witch ever method will work fine.

One of the most important things to remember about this trap is the Trigger. Should be 7-8" Long, And the Stake that goes in the ground

As short as possible, But Not the part that goes in the ground.

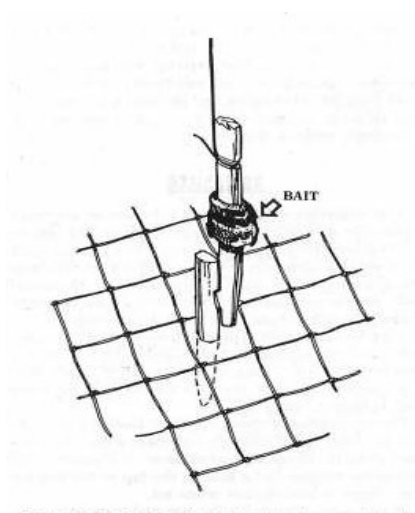

NOTE; MAKE Sure to place the net on the ground so that when it is Pulled Upwards it will not catch on the Notch of the stack that's in the ground. Cut one link in the net If Necessary. It will Not Weaken the Net Structure.

BAITED SNARE: Construct as for spring snare but using the release mechanism shown. The bait support is used to trigger . see bottom picture. Snare are place on opposite side of the Bait .

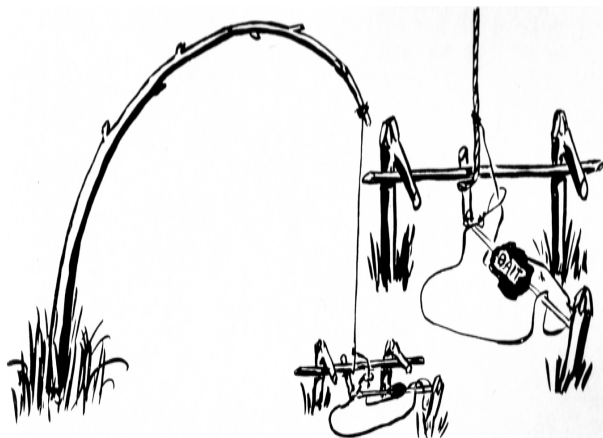
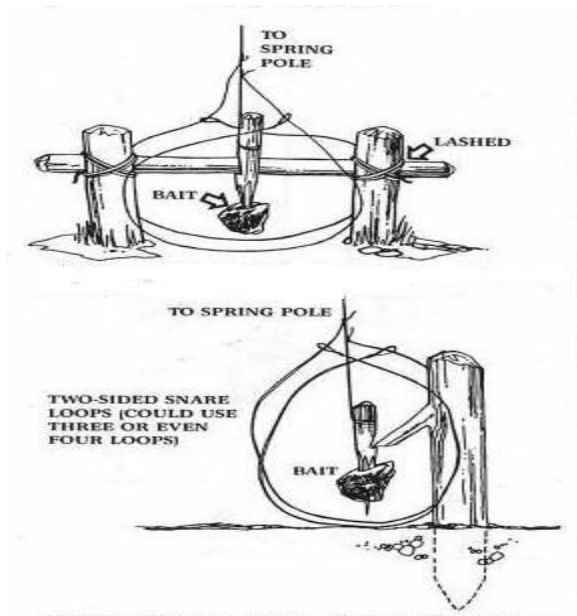

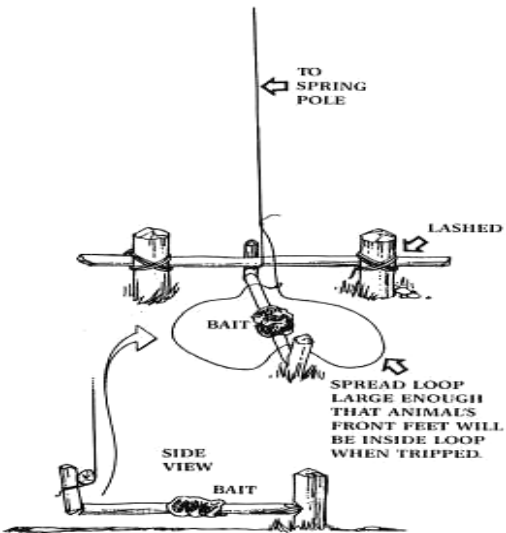

LEG SNARE : Push a natural fork or two sticks tied together into the ground. The line from a sapling is tied to a wooden toggle and the toggle passed under the fork. When the game takes the bait, attached to a separate stick, it falls away releasing the toggle which flies up taking the snare and the game with it. Large versions are amongst the best snares or heavy game.

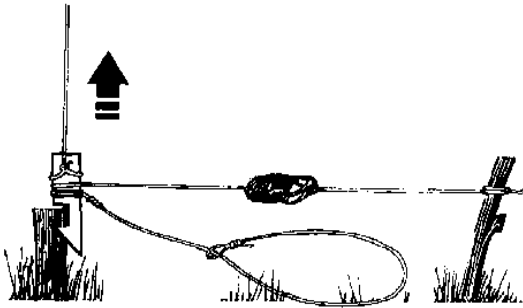

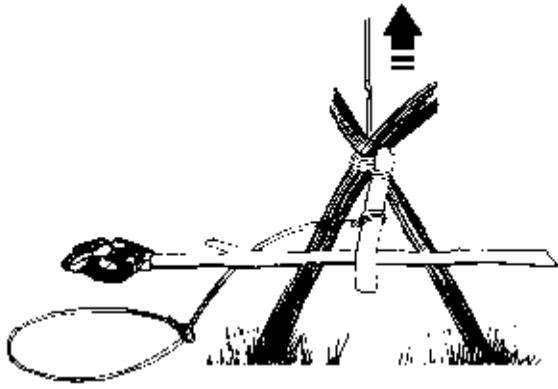

PLATFORM TRAP: Site over a small depression on the game trail. Snares on the platforms either side, when the platform is depressed the trigger is released and the game held firmly by the leg. For smaller, lighter game use the mechanism shown in (a), displacing either the bottom bar or the toggle will trigger the TRAP..

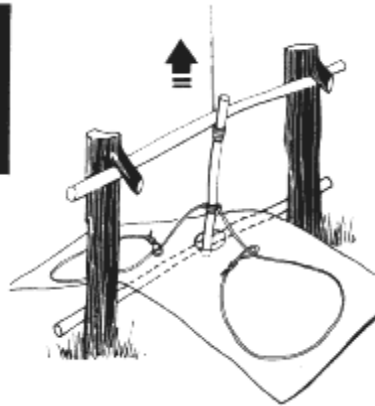

ROLLER SPRING SNARE:

A rounded grip holds the snare arm here, the switch line is best pulled back at a slight angle to keep it in place. Suitable for animals such as rabbits and foxes. Although tensed in one direction, the bar will be dislodged by an animal's struggles.

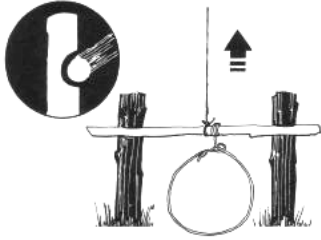

DOUBLE SPRING SNARE:- Two saplings are notched to interlock when bent towards each other over the game trail. A vertical bait bar is lashed near the end of one of them. Two snares can be attached to each sapling, they need to be fairly stiff to hold their positions. This trap is useful in clearings to catch small carnivores. When the bait is taken the game is help in the air between the saplings.

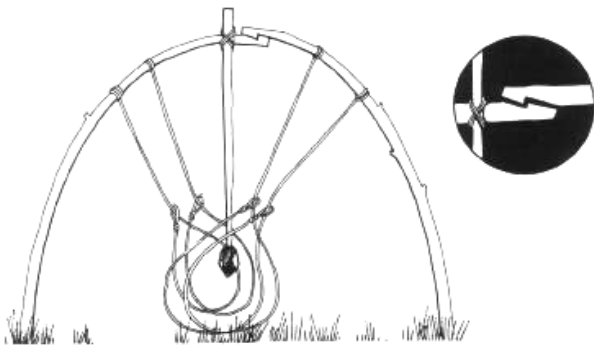

Treadle Spring Snare; Use a treadle snare against small game on a trail (Figure 8-11). Dig a shallow hole in the trail. Then drive a forked stick (fork down) into the ground on each side of the hole on the same side of the trail. Select two fairly straight sticks that span the two forks. Position these two sticks so that their ends engage the forks. Place several sticks over the hole in the trail by positioning one end over the lower horizontal stick and the other on the ground on the other side of the hole. Cover the hole with enough sticks so that the prey must step on at least one of them to set off the snare. Tie one end of a piece of cordage to a twitch-up or to a weight suspended over a tree limb. Bend the twitch-up or raise the suspended weight to determine where You will tie a 5 centimetre or so long trigger. Form a noose with the other end of the cordage. Route and spread the noose over the top of the sticks over the hole. Place the trigger stick against the horizontal sticks and route the co drag behind the sticks so that the tension of the power source will hold it in place. Adjust the bottom horizontal stick so that it will barely hold against the trigger. A the animal places its foot on a stick across the hole, the bottom horizontal stick moves down, releasing the trigger and allowing the noose to catch the animal by the foot.

This Trap is shown in the New 2007!
RANGER HAND BOOK.

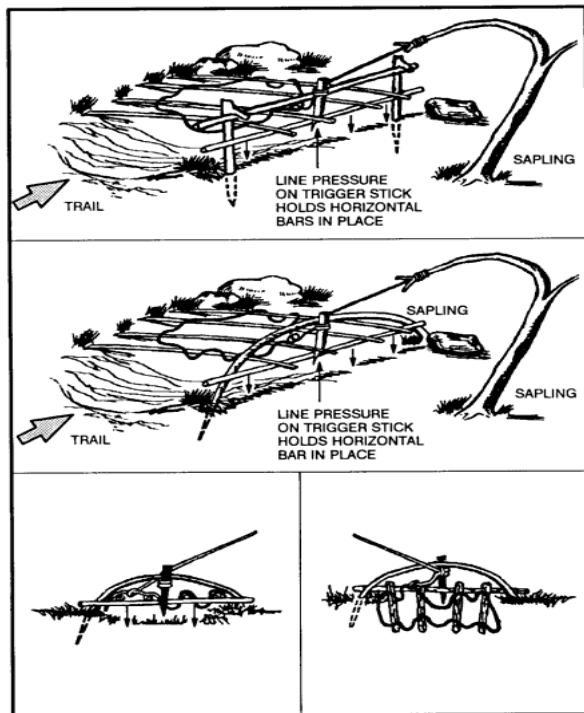
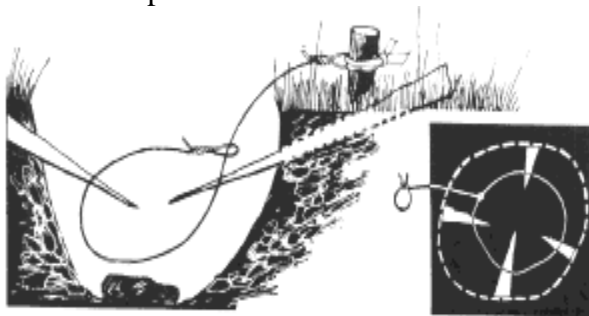

Figure 8-11. Treadle spring snare.

BAITED HOLE NOOSE : This trap is very useful for scavengers, drive 4 sharpened sticks into the pit, through the edges. Lay a noose across them attached to a peg outside the pit.



THE FIGURE 4. DEADFALL TRAPS: These traps all work on the principle that when the bait is taken a weight falls on the prey. All are good for game such as pigs, foxes, and rodents. Larger versions can be used for bigger animals such as deer and bears.

WARNING! The large versions of these deadfall traps can be extremely dangerous for humans as well as for the prey for which they are intended. The toggle release and deadfall traps can easily be set off accidentally.

Even in survival situations ensure that everyone knows exactly where they are. In survival practice keep people away from them and never leave such a trap set up at the end of an exercise. You cannot set a large deadfall trap on your own. Keep the mechanism to the side of the trail, well away from the dropping weight, or setting it will be too risky. Balance is critical, and you are unlikely to get it right the first time.

A horizontal bait bar is balanced at right angles to an upright with a lock bar, which supports a rock or other heavy weight pivoting around the tip of the upright.

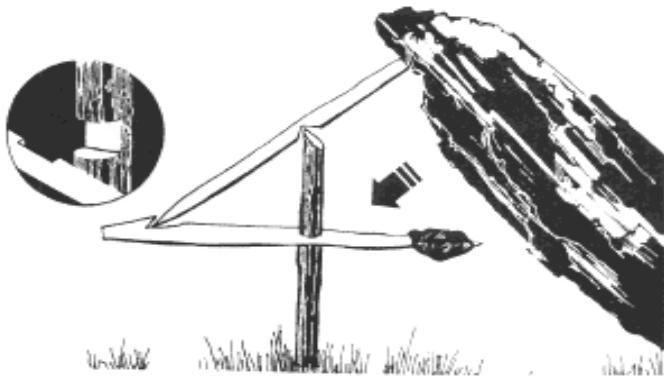

The figure 4 is a trigger used to drop a weight onto a prey and crush it . The type of weight used may vary, but it should be heavy enough to kill or incapacitate the prey immediately. Construct the figure 4 using three notched sticks. These notches hold the sticks together in a figure 4 pattern when under tension. Practice making this trigger before-hand; it requires close tolerances and precise angles in its construction.

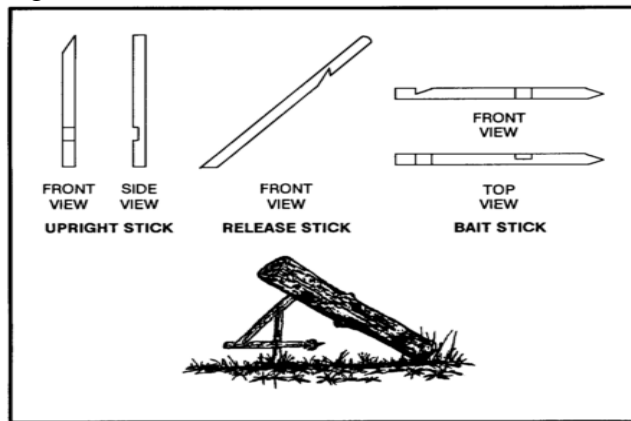
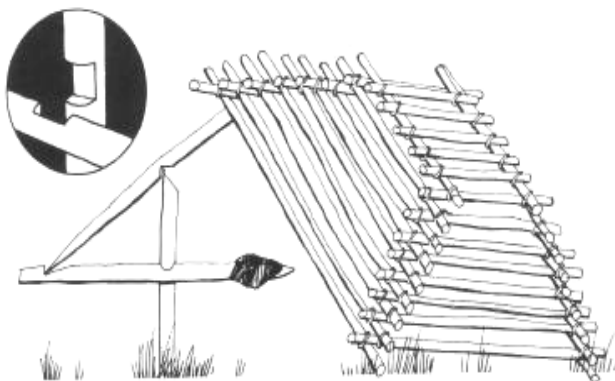

Figure 8-12. Figure 4 deadfall.

TRAP:- This mechanism can be used with a ‘log cabin’ type cage, made from a pyramid of sticks tied together, which is balanced over the bait. Scatter bait around and under the cage.



Peyote Deadfall

The Peyote deadfall is similar to the figure 4 but uses a piece of cordage and a catch stick (Figure 8-13). It has the advantage of being easier to set than the figure 4. Tie one end of a piece of cordage to the lower end of the diagonal stick. Tie the other end of the cordage to another stick about 5 centimetres long. This 5-centimeter stick is the catch stick. Bring the cord halfway around the vertical stick with the catch stick at a 90-degree angle. Place the bait stick with one end against the drop weight, or a peg driven into the ground, and the other against the catch stick. When a prey disturbs the bait stick, it falls free, releasing the catch stick. As the diagonal stick flies up, the weight falls, crushing the prey.

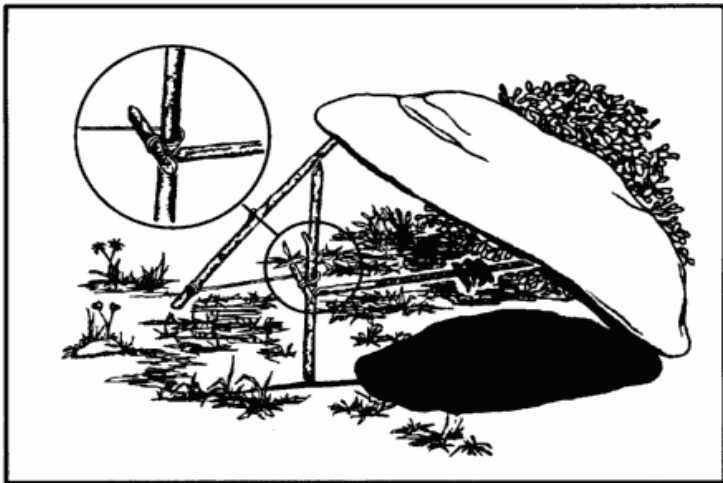
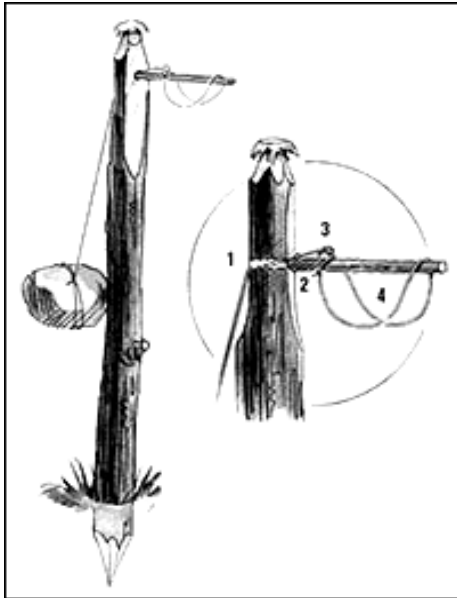

Figure 8-13. Paiute deadfall.

BIRD TRAPS;



Hook and Spring Pole Snare

This trigger is effective but can sometimes stick or release unexpectedly, especially if using green wood

Ojibwa Bird Snares

Bird lands, perch drops, knot slips through hole

Squirrel Snares

Dean Johnson

Better

This trigger can release hard with small animals

Must reply on animal stepping on treadle, best to keep it simple →

~ 31 ~

How to Skin a Rabbit;

Drape the noose over both sides of the trigger and insert it into the pole (if it's breezy, wet the cord with saliva to help it stay put). Draw the cord until the knot catches at the point where the trigger fits into the hole, to keep it from falling back. Skinning should be carried out in a manner that ensures the largest possible skin surface, which is an important part of its value. The first cut is usually an incision at the hind feet, passing from one thigh to the other. The skin is then pulled off. The skin on the head is of no commercial value, but it is preferable to keep it because it allows better stretching. This operation should be done with care, to avoid mutilation. All these defects reduce the value of the pelt.

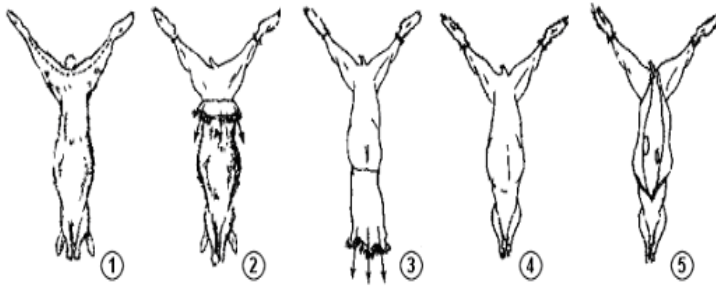

1. Skin cut between the thighs
2. Skin pulled off the hind legs
3. Skin pulled to bare the trunk and then the forelegs .

4. Carcass skinned but not eviscerated
5. Carcass opened, viscera (intestinal tract and lungs) removed

The Correct Way to Dry a Rabbit Pelt

Drying should start immediately after the skin has been removed. It must cool off quickly and dry out to prevent the action of enzymes in the derma, which attack the hair root and cause the hair to fall out. The skins are shaped on a frame. They should be dried in the shade or in the dark in a well-aired dry place. You can also make the frame with branches.

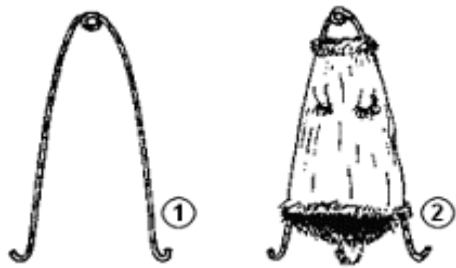

1. Frame of thick steel wire covered with plastic or sticking-paper
 2. Skin stretched over frame to dry, turned inside out with frame on inside, held down by clamps or domes pins
- Curing.

The pelt is processed to a semi-finished stage.

- **Dipping – dehydrating with water, salt, and soap; rinsing**
- **Fleshing – removing the thin collagen us layer on the flesh side**
- **Dressing – tanning with salt, alum, and formal**
- **Thinning – refining the thicker skins; dressing again**
- **Greasing – infusing the skin with oil**
- **Finishing – degreasing, beating, and lifting the hair**

Glossing

The final finishing operation applies to the hair for its special effect, involving shaving and dyeing. The furrier decides on the final appearance.

You will need 20–30 skins for one coat.

FISHING & SPEARS;

FISH AND FISHING:

Fish are a valuable food source, containing protein, vitamins and fats. All freshwater fish are edible, but some tropical ones can be dangerous. Leave any lines out overnight and check on them before first light. Fishing with a hook and line is the best way of fishing and should be a part of your survival kit. Hooks can be improvised from wire, pins, bones, wood and even thorns.

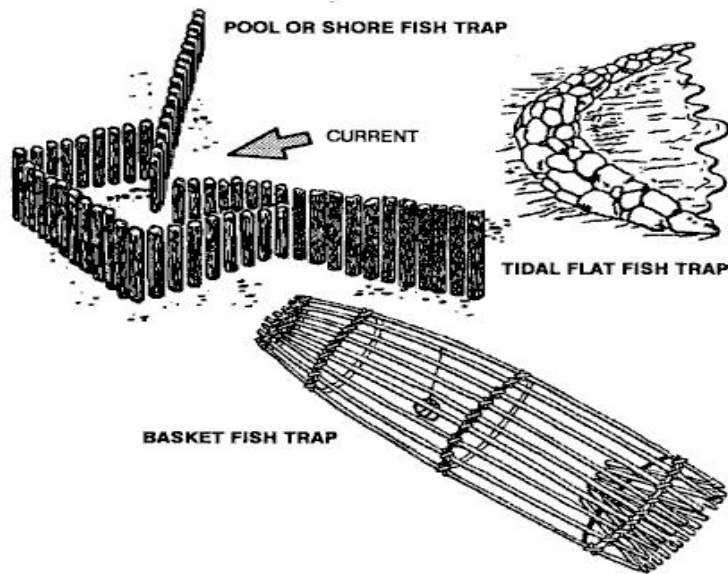

Bait native to the fishes' own water is most likely to be taken: berries that overhang it, insects that breed in and near it, parts of a fish, ants, worms, grubs, and other insects. Once you catch a fish, examine its stomach contents to see what it has been feeding on. I also add a few tied flies to my kit to use as well.

SPEARING:- Sharpen a long stick to make a spear, adding barbs to make it more effective. If you have multiple points, you give yourself a wider margin of error since it covers a larger area.

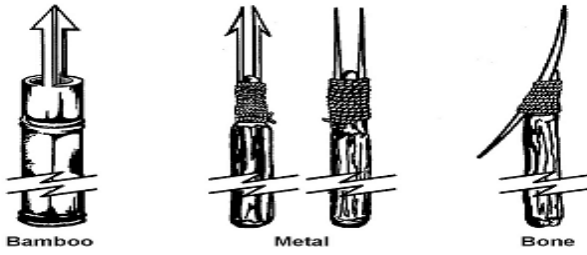

Try to get above the fish And strike down swiftly. Make sure that you are not casting a shadow over the fish you are trying to catch. Aim slightly below the fish to allow for refraction of its image at the surface.

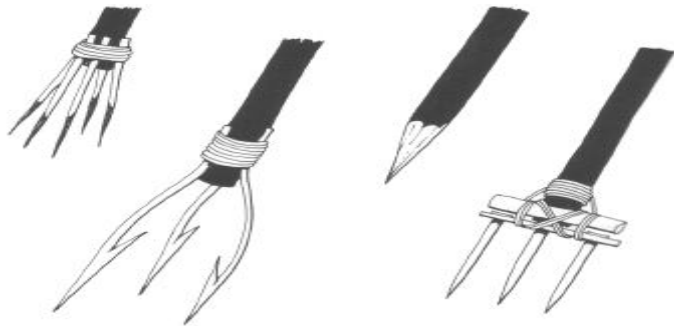

Fish hook`s

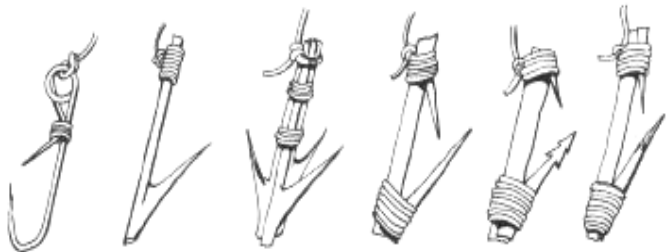

Fish Trap;

After dark, fish often cruise the shorelines of a lake or the shallow inside bend of a stream's ideal places for a trap.

Build it as shown with the materials at hand: logs, rocks, or stakes driven into the bottom.

The diversion arm of the trap directs fish into the V entrance. Most won't be able to find their way out. Close the entrance and net the fish with a seine made by tying a shirt between two poles. This is much more effective than trying to spear

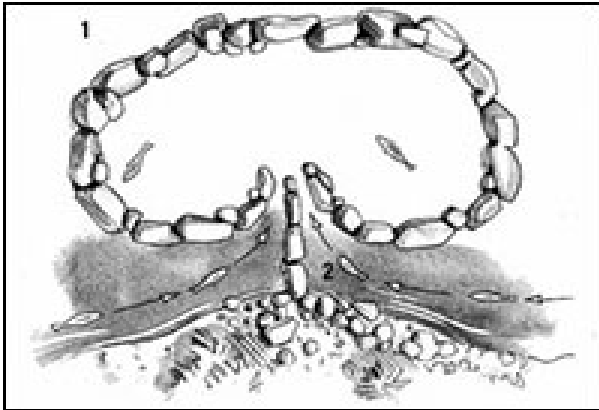

► SKILL 19: FUNNEL TRAP

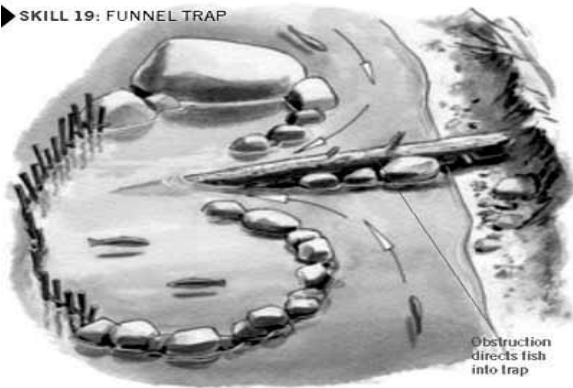

ALARM TRAPS

The tin can alarm trap, Is A great trap if you have no trip flares. Makes a heck of a racket.

Set a stake on the ground with a nail Or A wood trigger realise. And rig a whittle peg relies. Run the cord over a limb and tie about 10-20 tine can's. instead of running it to a spring pole. String a trip line across it to the whittle peg. Loosely is the Key word. When the trip line is tripped, the cans will fall with A Loud Racket. You can even have them fall on your Intruder. LOL,.

Their are deferent types you can make the key thing is for them to make Noise. So I'll Give You a Heads-UP,! Go To A Fire-Works Store, LMAOOoo This Trap will keep you alert to someone intruding in your L.Z.

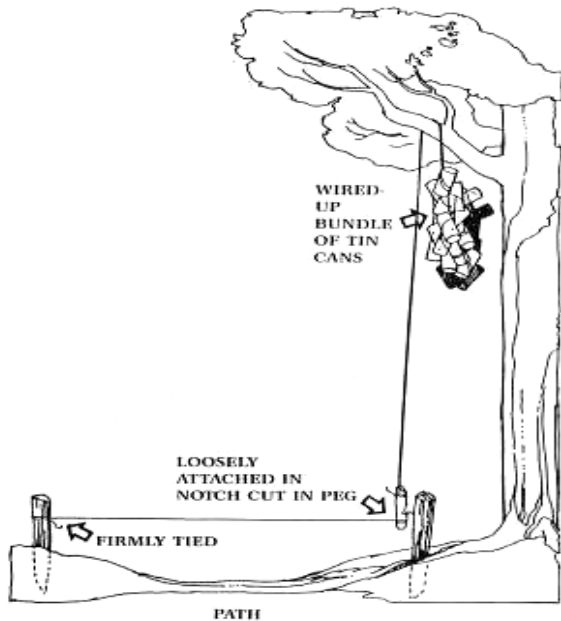

For this Noise Trap; You can rig a Flash-bang grenade, trip flare, Or a grenade if your in Combat. These Traps are great for Night Activities. As you can see the trip wire or rope is exposed, On Wide Paths, Sooooo, can be SEEN. Now: This Trap Is Great For Fire -Works. Get Fire-Works That Have A PULL-string, To trigger Them, You have some with 2 Strings at each end also, LOL. That Flash-BANG,! They Work GREAT. LOL.

If setting up in day time, use high grass or small brush, Young sapling type Field, Or in wooded areas with Knee Or waist size cover, or high cover. Like jungle, As examples. The KEY is to camouflage the tripe wire.

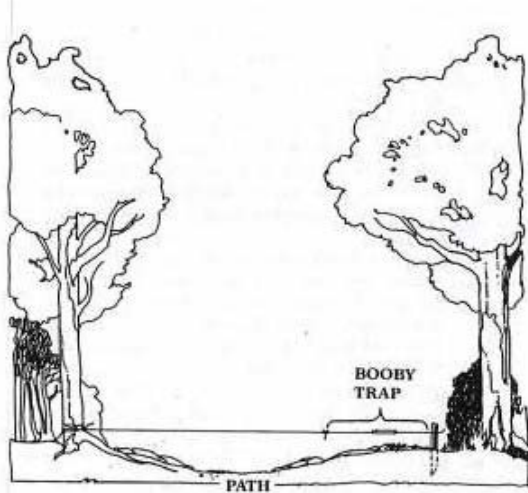

THE CRUSHER;

This trap leaves up to it's Name, Make no Mistake about that. Was used in the Move Predator. This is the trap That Stops, at the End, the Alien. Crushed HIM! Yikessss.

This Trap is set up same way as the tin can alarm Trap. If you want the log to fall faster. If You can climb the TREE, Cut A Canal, A little wider then the Rope, remove the Bark were the rope creates friction on the top of the branch.

Do Not, EVER stand under the Log, When, set Up Or setting it UP. Or you will be squashed. NOT GOOD!



DEADLY PUNJI TRAPS

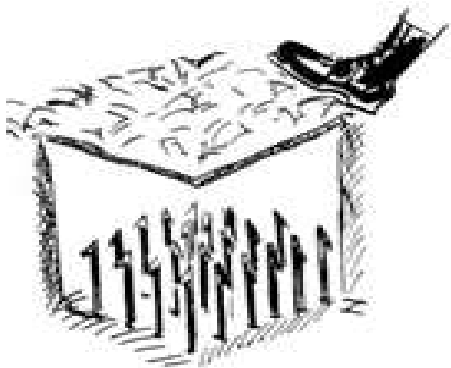

PUNJI TRAPS

These Traps will, Gore You, chop You Up, Or KILL YOU It's A Gruesome way to DIE,!

DO NOT ATTEMPT TO BUILD ANY OF THIS TRAPS, ! UNLESS You Have Practiced Making, Traps & snares. And have Built-Up Knowledge, confidence in build them.

ONLY USE THISE TRAPS In COMBAT, Or Survival.

Never Stand On The FRONT Swing Of these Traps. When Working On Them Or SET-UP .

ALWAYS APPROACH Or Work On These Traps From The Back Side.

And When Practicing Building This Traps, NEVER leave Them unattended. Mark The Aria.

& When Finished, Always DISMANTLE Them,!

Introduction;

The Punji; Stick, have been around for Thousand's of years. The chine's & Japanese used it in World war I and II

Used in the Korea war,. And made Famous In Vietnam. A Demoralising & Deadly LOW TECH Trap,!

Bamboo Is Hallow Circular, And When Cut to a Sharp point, Razor Sharp.

So when it Goers YOU, It Removes Out Chunks of Your insides, Basically leaving You with BIG Holes. You can Use Wood Spikes also, But Not same type of Damage.

Heads-UP; and This happened Many times, until, Command changed Pathfinders, criteria for land Large Groups. More Vigorous Inspection Of L.Z. And then changing to Choppers to Transport Troops.

The American's Had decided to set up advance bases, Send 600 Airborne, & S.F.

They sent in, an Advance Team of 4 Pathfinders, To Recce, The Area and Mark it for Night Landing. The Pathfinders where sent in, But landed on a semi wooded Aria.

They found LARG Open Grass Fields MANY, With Knee To waist high Grass. They Never Walked into the Fields, or Inspected them, Just Called their location to Command. While they sat in the wooded aria under cover. So they could just walk around the fields and Mark them, For landing.

**Note: Remember, walking in open
Fields, Should be avoided at all times!
Unless being inspected for Jumps.
Landings Or Theirs No Choice.**

As the planes where around 20 minutes away they started Setting up the Jump Markers! For 4 L.Z. each Pathfinders taking One Field to set-Up & then to Guide their way to a rendezvous point on the Edge of the wood line, Around the fields, after Landing.

The planes approach the Jumpmaster radioed in and started the first Wave! As the troops neared the ground a second Way Started The Jump.

As the first wave started touching ground LOWED, Horrifying, Yelling & Screams Was heard, From all 4 fields. SO MANY!

The Jumpmaster turned his flashlight on. Ran into the field, with in 10feet, he started , Bumping And Seeing. Pointy, Bamboo Sticks, Sticking out of the ground Just 1foot under the grass line, & 1 1/2 feet of the ground, Pointing Straight-UP. every foot or less, they were Planted Firmly into the ground, Like If They Had grown their.

The Fields Wear Littered with them. They called IN An Emergency Stop To The Pilots, But TO Late The 3rd wave Had Just Jumped! As More Waves where Preparing.

The jumpmasters saw Sooooo, Many Dead, Others Still alive,! Screaming in disbelieve, & horrified Agony. As They Laid Nailed to the ground.

Bodies Literally Gored, in several places , With inner body parts, Exposed On the Tips of the Punji-Sticks & around The Troopers. Some landed in the wood area, and around the fields, They were speared .
160+++++++ Men died! That night, and so many injured.

Americas best Trained Soldiers, their Finest,! Decimated & demoralized, in 15 minutes, By A poorly equipped and trained, Peasants FARMRS,! And A LOW Tech Trap.

Gave Airborne & S.F. a hell of a reality Check.

Ask any NAM Vets, That were debriefed before A Mission, & told they were going to Assault Or Operate in an Aria that was full of Punji Traps, !
Silence and fear would filled the room !

Would Scare the Hell Out Of ME! I know what this traps can DO,!

The American Airborne And Special Forces , After So many incidents. And looses. Treaded in there Parachutes for Choppers, To displace Large groups.

But as you will see By Picture on Next Page (46), The V.C. Adapted and improvised, Now that the U.S. Was using Choppers. The V.C. Upgraded the Traps in Large open fields, Or Small. Where it would allow Choppers to land.

HELICOPTER EXPLOSIVE TRAPS

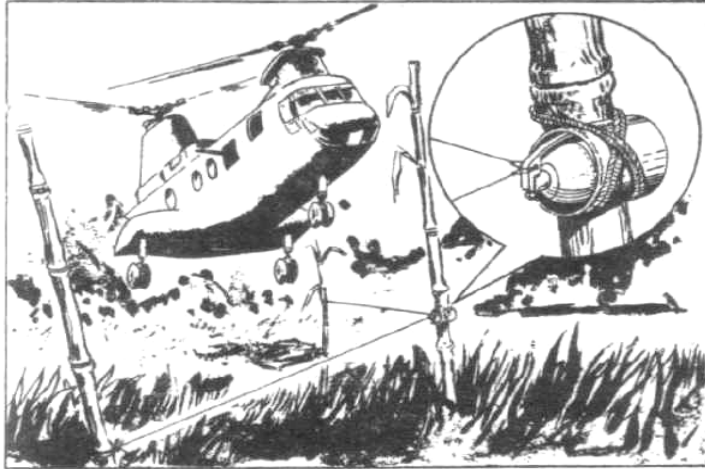

Punji Trap;

A Heavily used path-guarding trap in Vietnam, was a shallow pit. Made of Punji-sticks, Pointed up ward from the bottom . Witch was covered over, to make it appear like solid ground. Punji sticks are simply Sharpened pieces of Bamboo. Though any type of sharp stick can be used, bamboo was convenient in NAM. The sticks were placed in these foot traps with the sharp ends, pointed up wards. The other end driven into the ground. They were dipped in human Excrements & urine, so the wound would become infected.

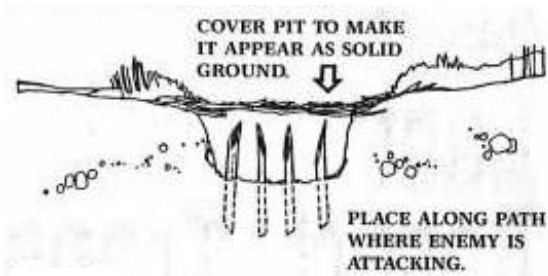

Same principle as sticks stuck in the ground,
Instead made out of metal, and Barbed at the end,
much faster to set-up.

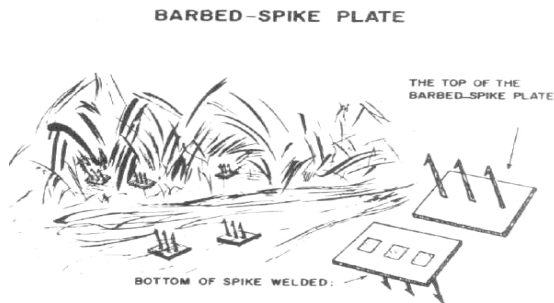

Spike Trap Box

This device is a simple wooden box made of boards
joined together with four corner posts.

The box has a lightweight-top but the bottom is
removed. Barbed spikes are placed in the
ground at the bottom pointing upward. This trap is
usually set up on dirt roads and trails to
take advantage of favourable camouflage.

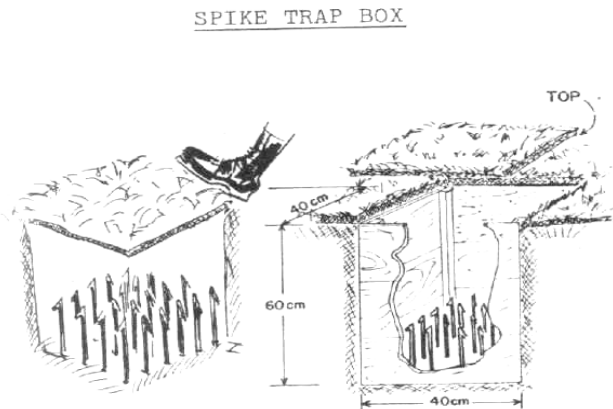

After " CHARLIE " learned that the Vietnam-Style Jungle boots American G.I.s wore were at least half-way puncture resistant, And high Tops. The V.C. Started setting the Punji-traps to work above the tops of the Boots. That's what I call Adapt and Improve.

The picture below shows the basic trap, except that the punji-sticks face downward, at an angle. When you step into the hole, your foot goes down in all the way. The normal reaction, Of any individual would be to jerk or lift your leg back up. This will cause the sharpened spears to puncture the leg, above the boot top.

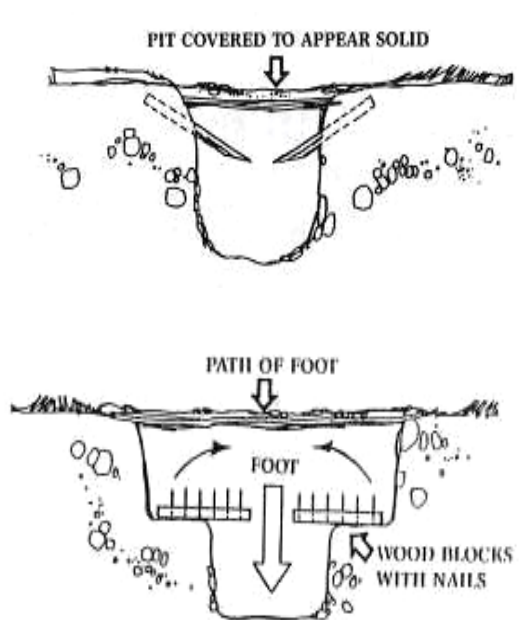

Punji Bear Trap;

This booby trap was built basically in the same fashion as the Punji Stake Pit. Instead of one uniformly shaped pit though, this hole consisted of two different sized holes-a larger hole on top of a smaller hole. The VC would place a bear trap over top of the smaller hole so that when the victim's foot penetrated the brush covering, it would land on the trap causing it to snap shut in an upward motion. There was hardly any escaping the trap's grasp on the victim's foot.

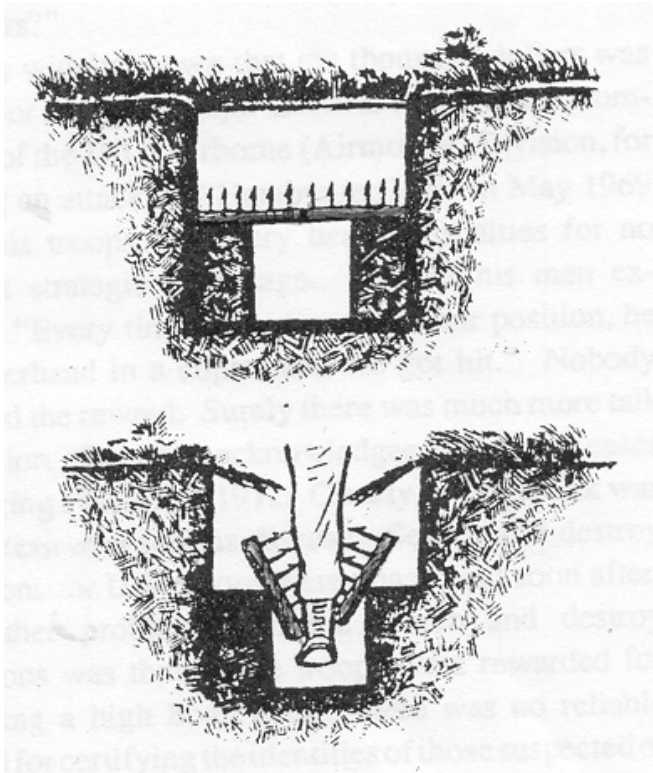

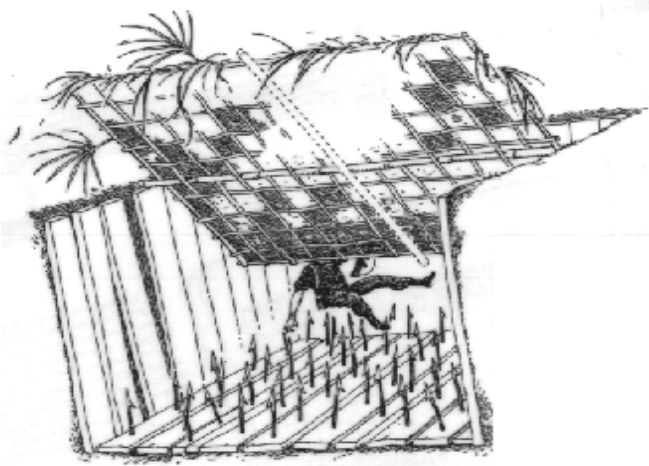

SPIKE TRAP PIT

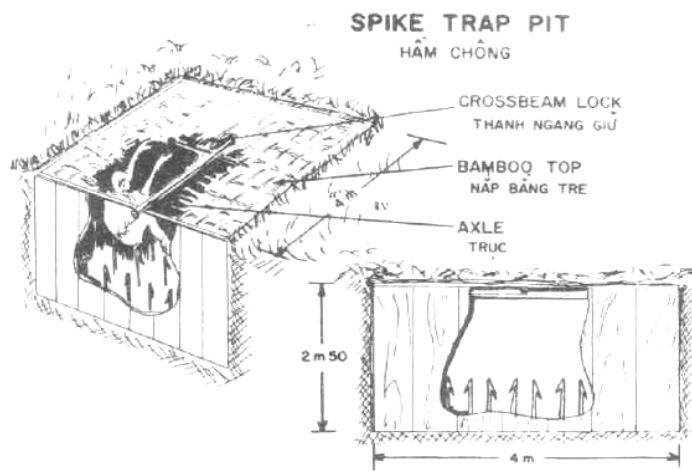

The Bow trap;

A bow trap is one of the deadliest traps. It is dangerous to man as well as animals. To construct this trap, build a bow and anchor it to the ground with pegs. Adjust the aiming point as you anchor the bow.

Lash a toggle stick to the trigger stick. Two upright sticks driven into the ground hold the trigger stick in place at a point where the toggle stick will engage the pulled bow string. Place a catch stick between the toggle stick and a stake driven into the ground.

Tie a trip wire or cordage to the catch stick and route it around stakes and across the game trail where you tie it off. When the prey trips the trip wire, the bow looses an arrow into it.

A notch in the bow serves to help aim the arrow. In some cases, these were set up with more than one arrow. All the arrows were tipped with feces. The trigger is a trip wire.

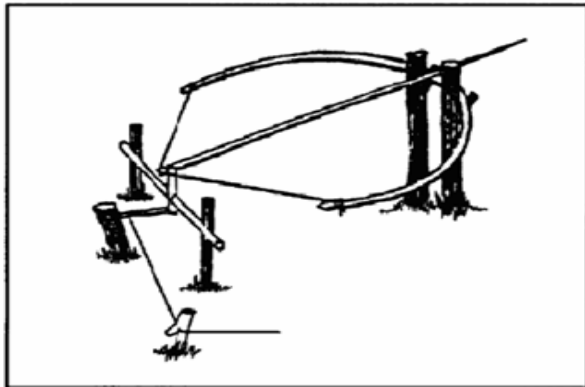
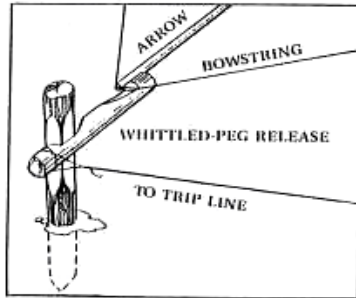
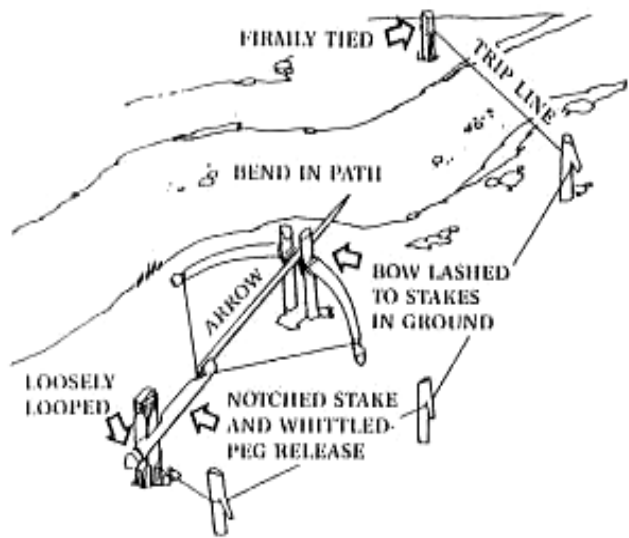

Figure 4-14. Bow trap.



Note: The way for you Set up your elevation, will determine your aim, by the height at witch the bow is lashed to the stakes, The trigger-stake height, and the whittle peg will also determine the aim and height the arrow will travel . you can take a few practice shots to see where the arrow will go. Please note; I have used 2 arrows & works just fine. LOL.



CANE OR BAMBOO SHARPENED ARROW

NAIL ARROW

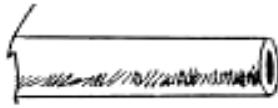

WOODEN ARROW

SAME ARROW AS ABOVE EXCEPT WITH WHITTLED-WOOD ARROWHEAD CARVED TO FIT IN HOLLOW END OF BAMBOO OR CANE. SEAR ARROWHEAD WITH FIRE TO HARDEN. CAN ALSO USE HAMMER-FLATTENED NAIL FILED TO SAME SHAPE FOR ARROWHEAD. USE MUD TO FIRMLY DRY NAIL IN BAMBOO END.



STRAIGHT LIMB ARROW
{NOT CANE, SOLID}



"BLANK" ARROW

TIE ONTO BLUNT ARROW SMALL CLOTH FILLED WITH PADDING TO FORM A NON-PENETRATING ARROW.



Feather can be glued , Or stringed on any of this arrow designs. If desired and if materials are available.

CARTRIDGE TRAP; This trap consists of a piece of bamboo and a cartridge. Or Any cylinder that will hold the casing. A nail is driven into the bamboo about 2" from the bottom to act as a firing pin. A piece of wood is fastened to the piece of bamboo to hold the nail. The cartridge will protrude 2" from the bamboo. The primer of the cartridge is right above the head of the nail. When a man steps on this trap, the cartridge will hit against the nail, explode, and hit him. This trap is generally installed in the ground on the shoulder of a road and along paths.

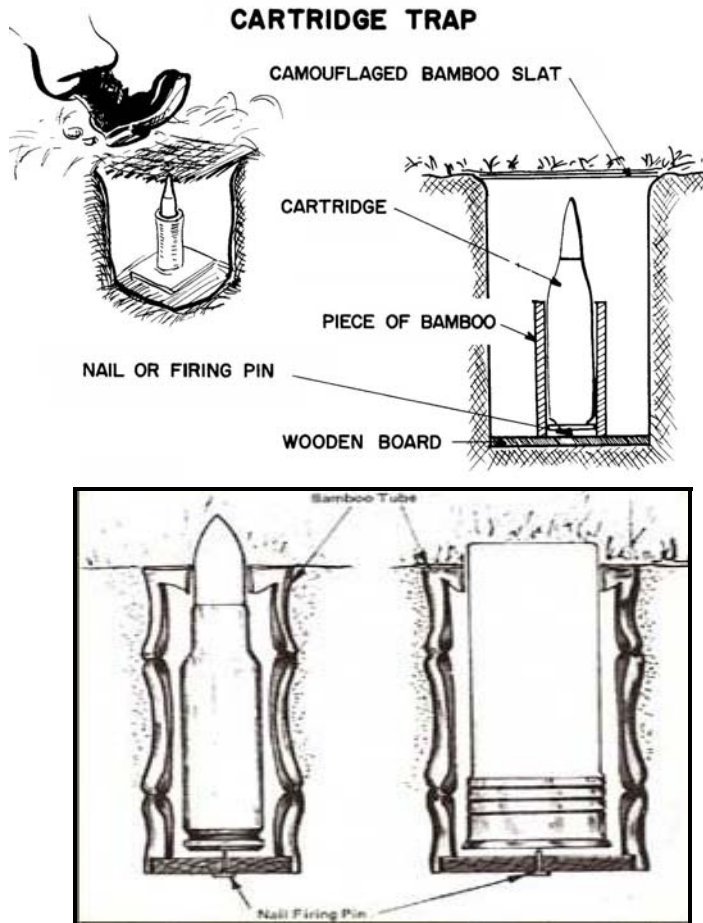

BAMBOO WHIP;

A strip of springy bamboo from 3 to 10 feet in length is used to make a bamboo whip. A barbed-spike plate is secured to the tip of the bamboo (or several of the spikes driven through the bamboo), and the whip is drawn back and secured. A tripwire is then latched to the whip and the wire is strung across the trail. When a man trips the wire, the bamboo is released, and whips around, striking the victim with the spikes.

BAMBOO WHIP

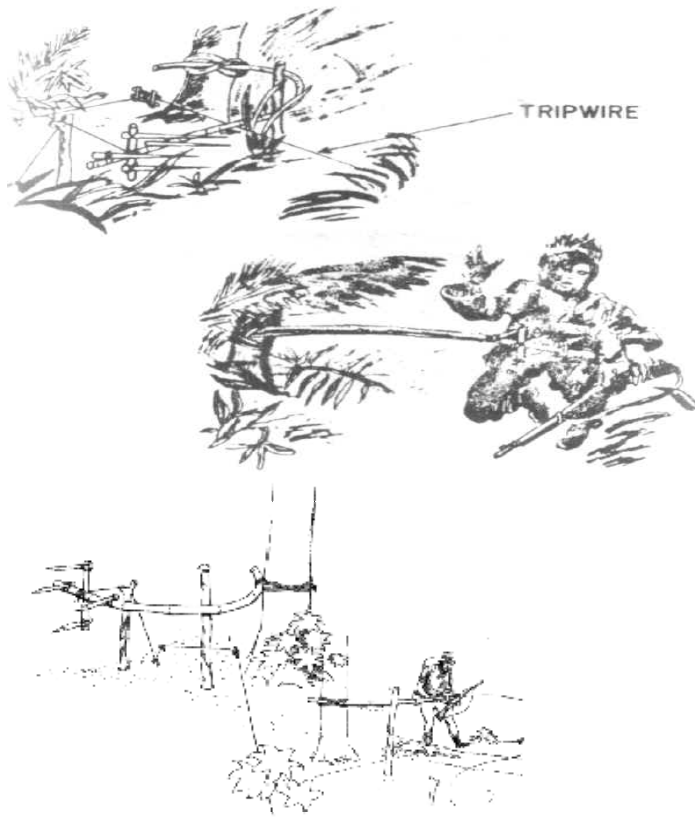

The Stabber; Same as Whip

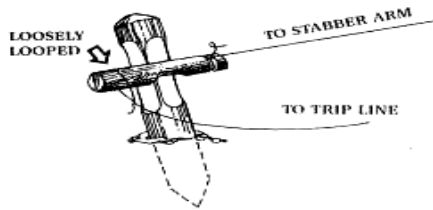
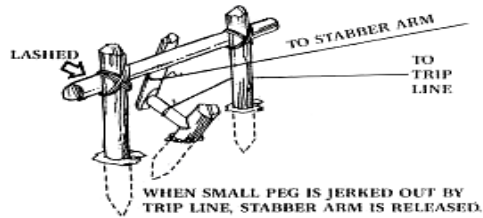
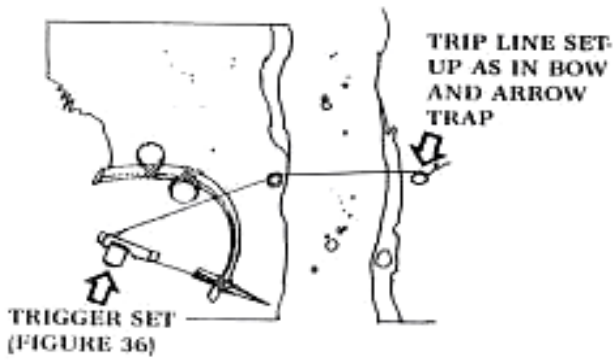
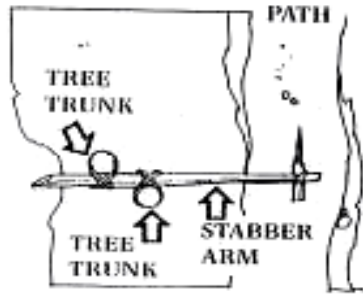

I Really do Not like the Trigger Set Up of this Trap;



This has the same Principle trigger as the Pig Spear. Except this is set up Horizontally. I find the Stabber has a better Trigger System.

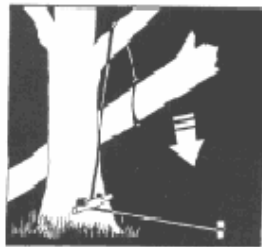
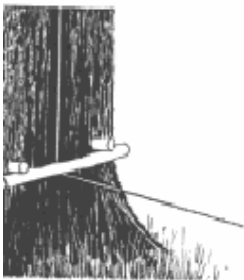

Pig Spear Shaft; To construct the pig spear shaft, select a stout pole about 2.5 meters long (Figure 8-15). At the smaller end, firmly lash several small stakes. Lash the large end tightly to a tree along the game trail. Tie a length of cordage to another tree across the trail. Tie a sturdy, smooth stick to the other end of the cord. From the first tree, tie a trip wire or cord low to the ground, stretch it across the trail, and tie it to a catch stick. Make a slip ring from vines or other suitable material. Encircle the trip wire and the smooth stick with the slip ring. Emplace one end of another smooth stick within the slip ring and its other end against the second tree. Pull the smaller end of the spear shaft across the trail and position it between the short cord and the smooth stick. As the animal trips the trip wire, the catch stick pulls the slip ring off the smooth sticks, releasing the spear shaft that springs across the trail and impales the prey against the tree.

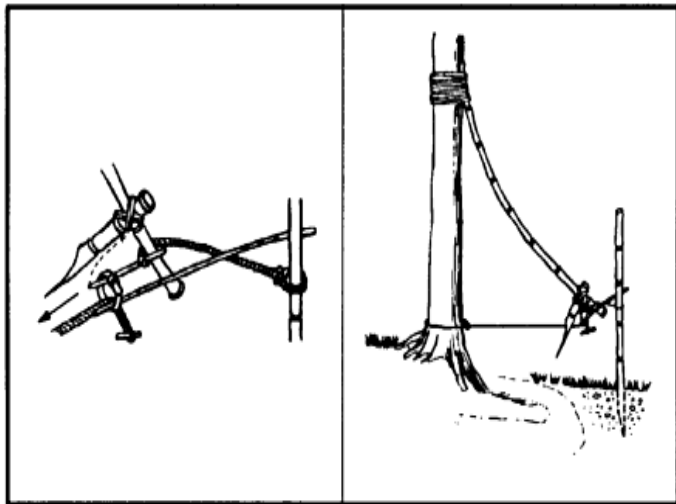
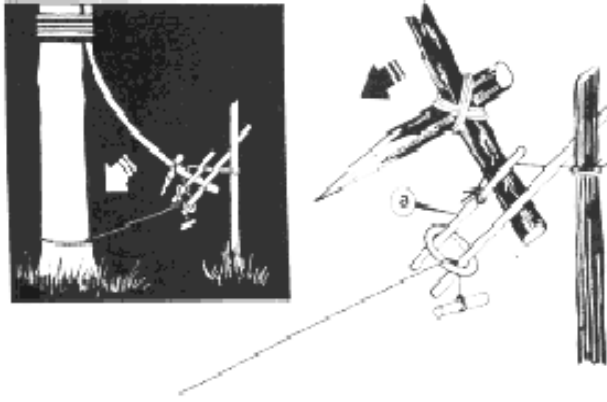

Figure 8-15. Pig spear shaft.



This is a VERY dangerous trap, it should always be constructed approached from behind the spring of the trap □ and only if you are confident that your cordage and other materials are strong enough.

A springy shaft with spear attached is suspended over a trail. A slip ring made of SMOOTH material is attached to a trip wire and acts as a release mechanism.

A toggle (a) and short line to a fixed upright hold the sprung shaft in tension. A further rod through the ring is tensed between the near side of the sprung shaft and the far face of the upright, securing until tripped.

Depending on the size of the spring, these pear points can range from just a couple of inches, to two feet in length. Many soldiers faced similar traps to these in the jungles of Vietnam. Bamboo is a great building material, and was used throughout the country for the dreaded punjii sticks. Again, the trigger for this trap is a trip wire.

The Arrow Trap;

This trap utilizes a bamboo tube (usually about 3 feet long) as a launcher. A steel arrow is placed in the tube using a block of wood as the bolt, a strip of strong rubber for power and a catch to lock the rubber strip, the device is fired with a tripwire. When the victim trips the wire, the latch disengages, allowing the rubber strip to launch the arrow.

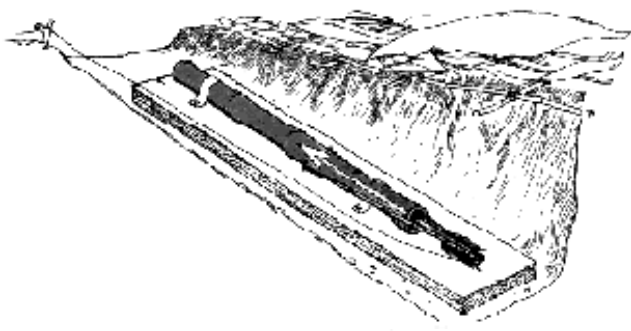

STEEL ARROW TRAP

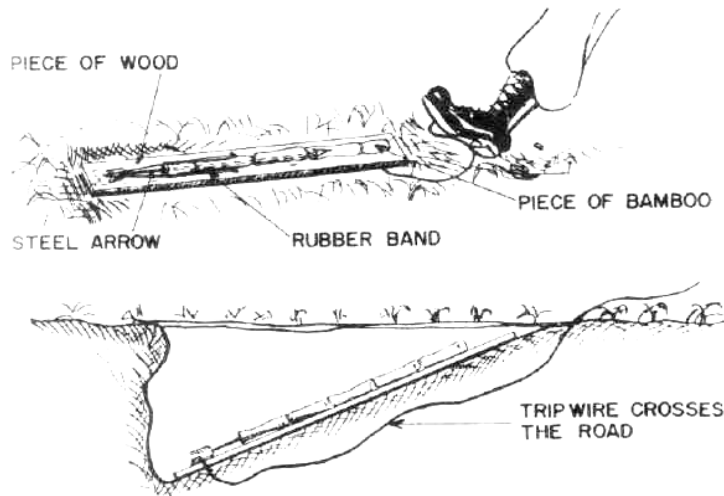

Fire By Friction;

Rather than creating a spark into tinder, fire by friction causes the fuel to heat up until it reaches the combustion temperature and ignites. This is around 800 degrees Fahrenheit. Moisture is the biggest obstacle to overcome when attempting to create fire by rubbing wood. Start with extremely dry wood and keep it dry to ensure success. In areas of higher humidity, more effort is required.

Following are some of the more common methods of creating fire by friction in order of increasing complexity. All of these methods create a coal of smouldering wood dust which is then transferred to waiting tinder to be coaxied into flame. They also employ one piece of hard wood and another slightly softer wood which wears away. Neither of these woods should be too soft nor too hard. Excessive resin in the wood will also cause failure since it will cause the wood to become polished and smooth.

These are simple introductions to each method. Individual success depends on strength, practice, materials used, and troubleshooting. These methods require a lot of effort and consistency. Some woods to consider using:

- **Cedar**
- **Willow & Redwood**
- **Yucca & Oak**
- **Birch**

Fire Plow;

1. Form a plow-board of softer wood that is flat and a couple inches across and 2 feet long.
2. Form a plow-stick that is hardwood and has a sharpened tip.
3. Cut or rub a depression about 6 or 8 inches long in the plow-board. This is the trough in which you will scrape the plow-stick.
4. Hold the plow-board firm as shown or kneel on it or sit on it if it is a longer board. The idea is to keep the board steady.
5. Point the plow-stick into the plow-board at about a 60 degree angle and push it forward with downward pressure.
6. Release the downward pressure and pull the plow-stick back to the start of the trough.
7. Push and pull the plow-stick quickly, creating wood dust at the far end of the trough.
8. It is important to end each stroke at the same spot so dust can accumulate there.
9. Eventually, the wood dust will combust and can be pushed into waiting tinder.

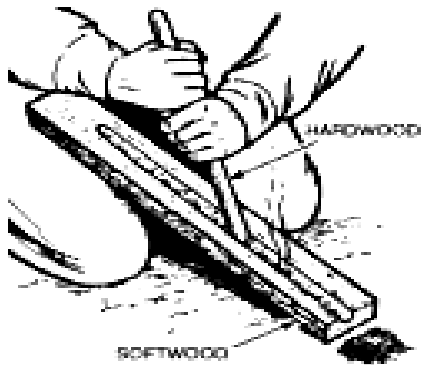

Hand Drill;

1. 1/2 inch wide, with very few side branches, preferably none.
2. Smooth the drill of all bumps, knobs, and roughness so it will not rip up your palms.
3. 1/2 inch drill. It should be about 18 to 24 inches long, 1/4 to 1/2 inch thick. Create a hearth board about 1/4 to 1/2 inch thick and 1 inch wide. Split a piece of softer wood to form a flat surface. Choose a straight stick of a harder wood for your fairly flat surface.
4. Cut a small depression in the top of the hearth board about 1/8 inch in from a side. This is where you will seat the drill.
5. Hold the hearth board firm with a knee and position the drill in the depression.
6. Spin the drill between your palms to wear out the depression and see that the drill seats well.
7. Carve a notch half way in to the center of the depression from the edge. As you spin the drill, the wood dust collects in this notch so place a piece of bark under this area to catch it.
8. Spin the drill, repositioning your hands at the top when they work their way to the bottom.
9. Over time, the wood dust will accumulate and ignite with smoke and finally a small ember. Transfer it to tinder.



Bow and Drill Fire Starter

Experience techniques used by native Americans for lighting a fire before steel was introduced. These methods can be used in survival situations today.

Materials

dowel (1/2" x 12" or 1 cm x 30 cm)

pine or hardwood board (1" x 2" x 12" or 2.5 cm x 5 cm x 30 cm)

pine board (1" x 2" x 4" or 2.5 cm x 5 cm x 10 cm)

green stick such as willow (1" diameter x 2' or 2.5 cm x 60 cm long, shaped as shown)

length of leather thong , & grease

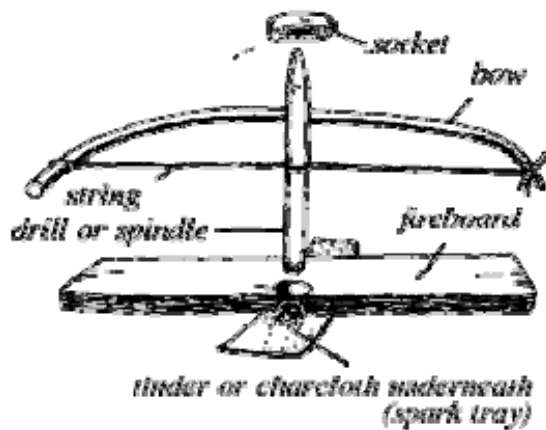

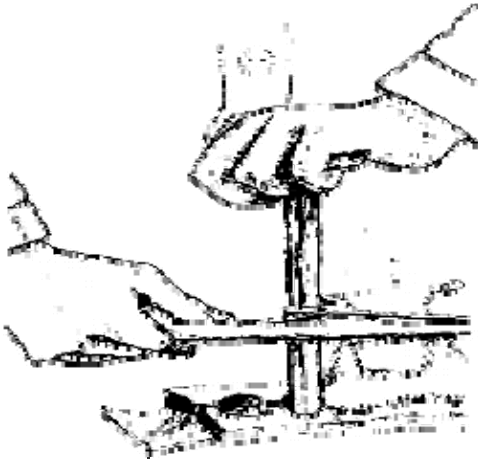

1. A bow and drill creates fire by friction. The drill and fireboard should be the same wood.
2. Round edges of 1" x 2" x 4" board so that it fits comfortably in your hand.
3. Drill or carve a 1/2 -inch (1 cm) diameter shallow socket in the center of the piece.
4. Round one end of the dowel and sharpen the other end to a short bevel.
5. Notch the foot-piece as shown and drill or carve a shallow depression.
6. Assemble the bow and drill illustrated. Note that the thong is wrapped once around the drill so that it spirals upward toward the handle.
7. Lubricate the head-socket with grease (ear wax will do in a pinch).
8. Place one foot on the foot-piece. Kneel so that the opposite knee is on the ground.
9. Sprinkle tinder in the notch of the foot-piece.
10. Insert the bow and drill in the socket of the foot piece. Insert the top of the drill in the head-socket.

11. Steady the hand holding the headpiece against the shin, while applying light pressure on the headpiece. Slowly saw bow back and forth. If drill does not turn, increase tension on the thong. Gradually increase speed until the bottom of the drill begins to smoulder.
12. When it is smoking well, give 20 or so fast strokes with the bow and pull the drill quickly from its socket. There should be a small pile of smouldering punk in the notch with the tinder.
13. Gently fold tinder over the smouldering punk and blow. As the volume of smoke increases, keep blowing until the tinder bursts into flame.
14. Do not expect instant results; this technique takes practice. Using a bow and drill will not always result in a fire, but it will create a deep affection for matches.

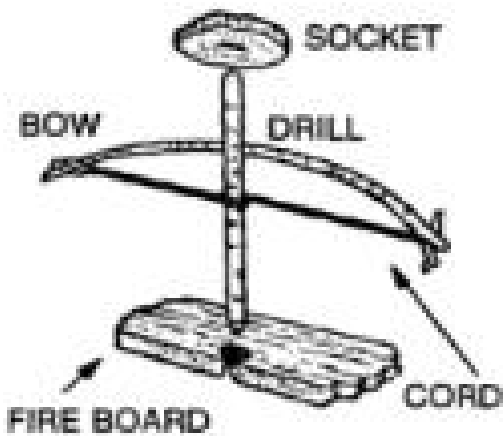

NOTE; The sizes Given for the Bow-drill, Are optional, Can be made in deferent Sizes.

Making Primitive Tools:

In prehistoric times , Stone tools were made from a variety of different kinds of stone. For example, flint were shaped (or chipped) for use as cutting, or chopping tools & Weapons, While basalt and sandstone were used for ground stone tools. Such as quern-stone. Wood, Bone, shells, Antlers and other materials were widely used as well.

**word: *Silex*, for hard stone (flints).
Subsequently, silicon, Silicon**

Flint is 98% amorphous silica which sometimes encloses fossils or micro fossils. Flint is always found in association with chalk although its origins are less understood. The biological origin of the surrounding chalk matrix is undisputed so the fact that flint is found within chalk and the fact that many creatures of the zooplankton have siliceous exoskeletons strongly suggests a biological origin for flint but gives no hint as to how the silica is concentrated and mineralized into glassy nodules.

Flints have been worked since the beginning of human prehistory.

Note; One of the most important implements in a survival situation is a good cutting tool. If you were to find yourself without a knife, a stone cutting tool can be created from rocks, And can save your life

Making Primitive Stone Tools for Wilderness Survival Situations



The Art of Flint Knapping

Flint knapping is the age-old art of making arrowheads and other edged stone tools. Hunter-gatherers relied upon this key wilderness survival skill to create important tools and hunting implements. Many people continue to practice the skill today, including traditional bowyers, experimental archaeologists, and primitive skills enthusiasts. At its most basic level, flint knapping consists of: breaking open a piece of parent material (called a core); striking flakes off of that core; and then shaping those flakes into the intended tool.

The first step to creating useful primitive stone tools is selecting the best-suited material. A riverbed or creek can be a great place to search for the proper stones.....

Look for;

- **fine grained stones with a consistent texture**
- **rocks that have the highest pitch when tapped**
- **stones that do not have existing cracks or fissures**

Percussion Flaking, Pressure Flaking, Notching.

Percussion Flaking

Percussion flaking is the act of striking your material to break it apart in a controlled manner. In a uniform material, the force from a strike moves out from the point of impact in a cone shape that is roughly 100 degrees wide. This is called a Hertzian Cone. Understanding this concept of how forces move through stone allows you to angle your stone to break it apart in an intentional way.

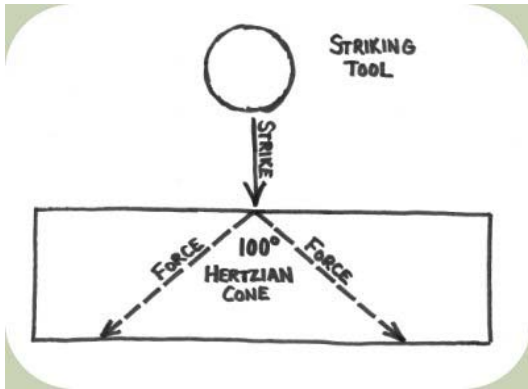

If your parent material (also called a core) has rounded edges, the first step is to break it apart so that you have good edges to work with. This can be done by using a large hammering tool. The goal is to create platform edges that are less than 90 degrees

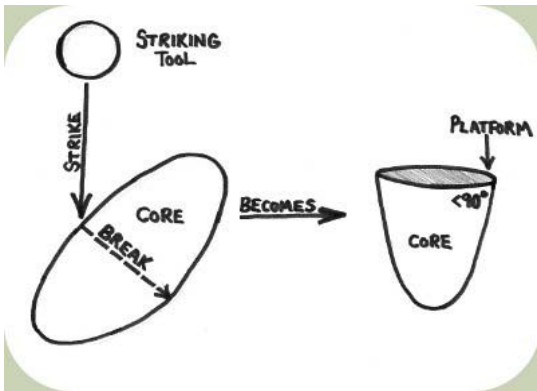

The next step is to strike flakes off of your core using smaller striking tools. It is these flakes that you will be further shaping into implements such as arrowheads .

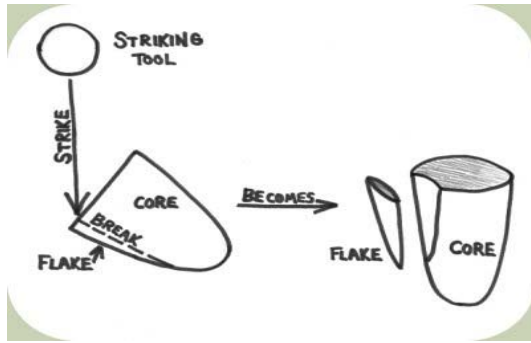

A core for many blades is prepared by breaking a large flint nodule in two with a hammer-stone. Using either piece, the maker then knocks long, thin flakes from the outside rim leaving a tapering fluted core. From this he produces a whole series of finished blades, striking them off one by one as he spirals around the nucleus.

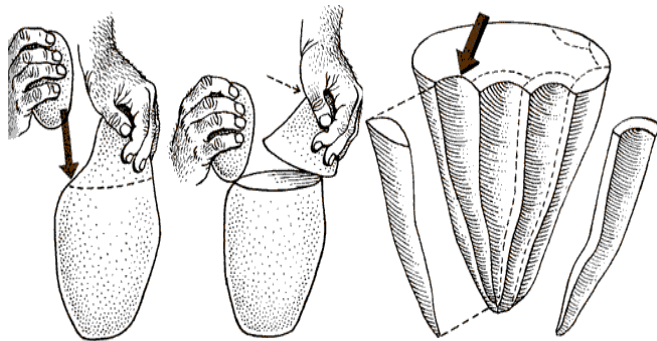

By striking between ridges he will get a hollowed blade (top right). It has been estimated that a two-pound nucleus, flaked in this fashion, will yield some 25 yards of working edge, whereas a hand-axe shaped from the same stone would yield about four inches of effective edge.

Shaping Flakes;

Variouly shaped flakes may be struck off fine-grained rocks by varying the angle and force of the blow and using different hammers. The principle is simple: radiating waves of force, like ripples in a pond, crack out chips.

Telltale signs exist on flakes which have been; they never occur on naturally broken stones.

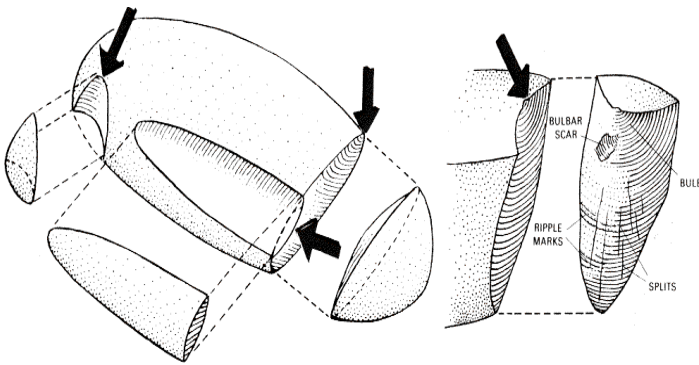

Pressure Flaking;

Pressure flaking is the act of using a pressure flaking tool (such as an antler) to load significant pressure against an edge and then popping off a long thinning flake. Pressure flaking allows a flake to be carefully shaped down into the finished tool. To pressure flake, an edge often needs to be strengthened by abrading it to remove thin weak pieces. A platform is then picked out, which is a point on the edge that sits below the centerline of your flake. The pressure flaking tool is then pushed onto the platform with significant force and a small thin flake is popped off of the piece. Picture On Next Page.

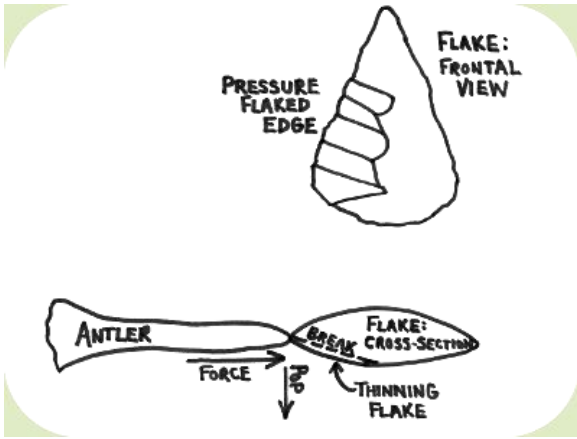

Notching is the final step in making arrowheads. The notches are made using a combination of pressure flaking and abrading to carve out the gaps that allow the arrowhead to be bound to an arrow shaft.

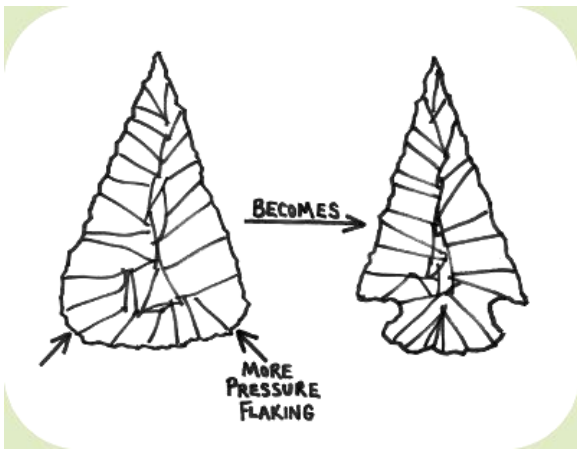

Pressure Flaking;

Using a pointed implement of wood, bone or stone, the artisan forces a flat flake from the lower surface of the tool by pressing against the edge in a slightly downward movement.

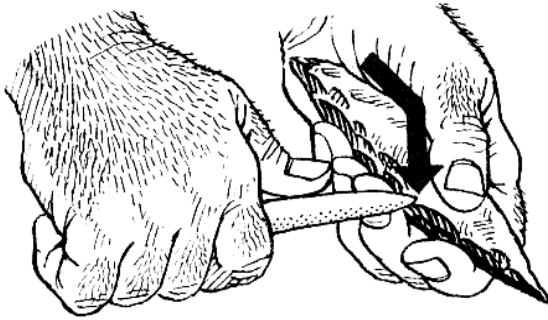

Shouldered Point;

End-on views of pressure-flaking show how force is applied to the tool edge itself. Controlled fracturing with this method results in finer flakes and finer tools, like the leaf point at right.

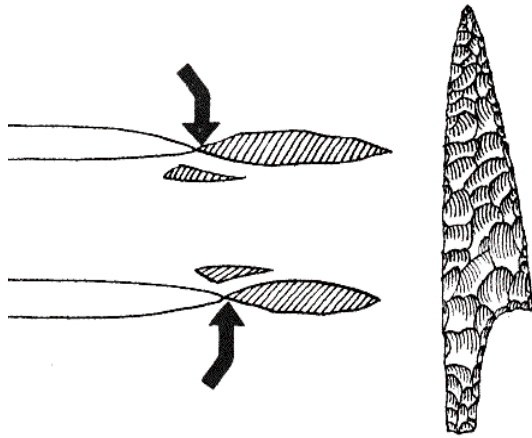

Baton technique;

Using a pointed implement of wood, bone or stone, the artisan forces a flat flake from the lower surface of the tool by pressing against the edge in a slightly downward movement.

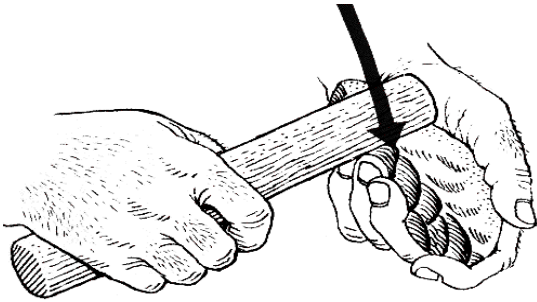

Acheulian hand-axe;

An Acheulian hand-axe shows the effects of delicate edge retouching by the baton method. With this technique, toolmakers fashioned especially sharp, straight-edged cutting tools.

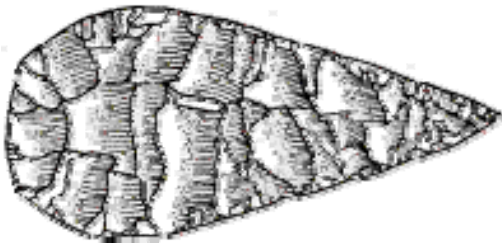

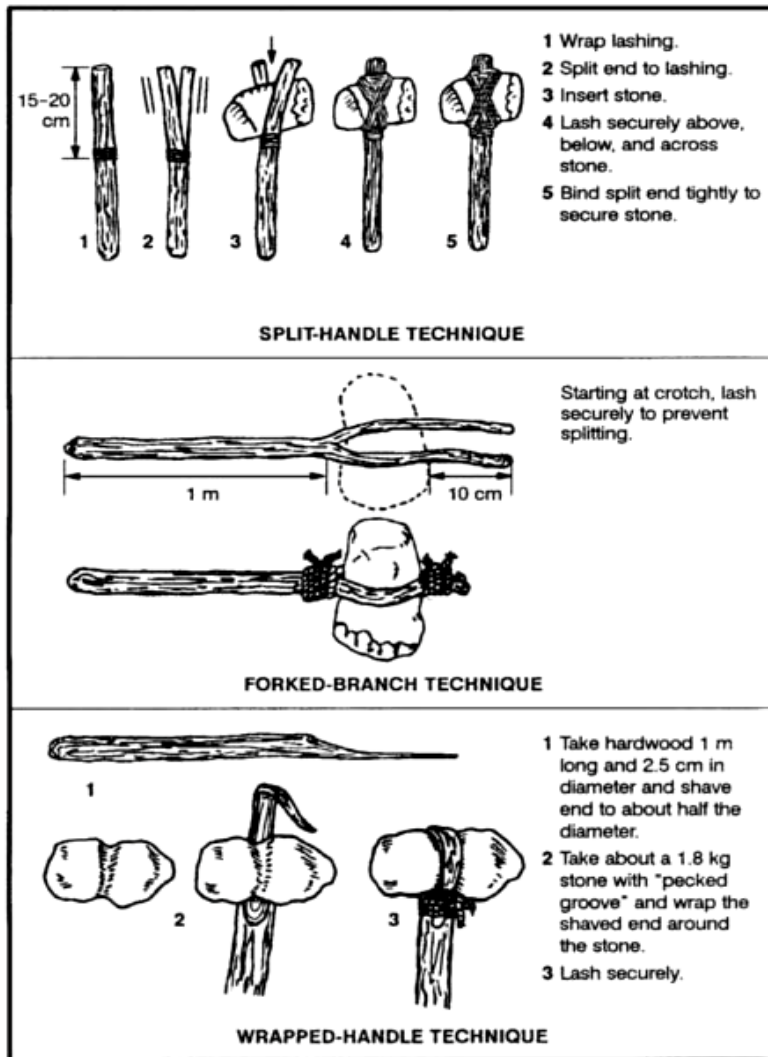
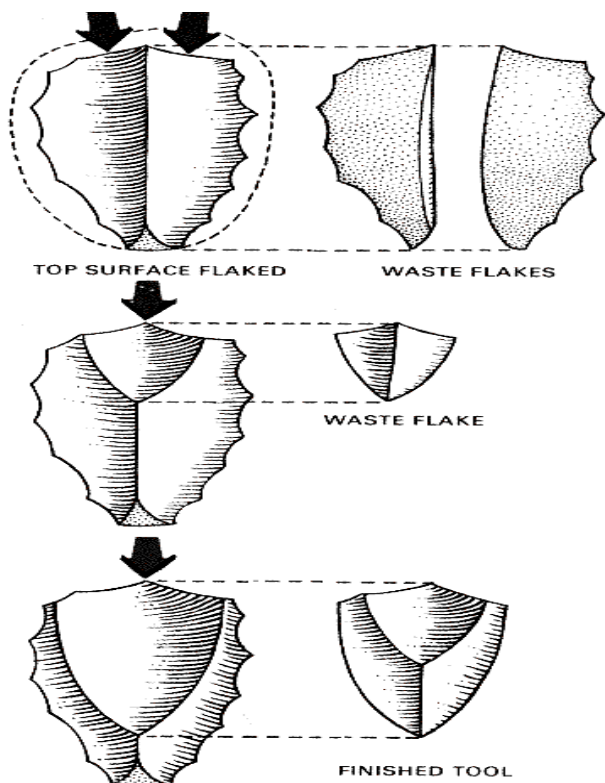

Figure 12-1. Lashing clubs.

Making a Levallois Point;

The levallois point is begun in exactly the same way, except that in the second stage, instead of chipping the top surface, the maker drives off two large parallel flakes (middle), leaving a ridge down the center. A light blow then removes a small flake from one end; one final blow drives off the point.





IMPORTANT: Please exercise caution when breaking stones apart. Small shards can project out in any direction. Eye protection is essential. Long-sleeve shirts, pants, and gloves are also recommended.

By utilizing the above techniques, you can quickly create a primitive stone tool to aid in a wilderness survival situation. Happy rock-breaking!

Knot Terminology;

To start, it helps to know some basic knot terminology.

Line: The rope or cord in which a knot is being tied

Working end: The end of the line used to tie the knot

Standing end: The end of the line *not* used to tie the knot (this end is often left out of images that show how to tie a knot)

Standing part: The section of line between the knot and the standing end

Bight: A stretch of line formed into a “U” or semicircle that does not cross itself (some knots can be tied using the bight of a rope rather than the ends; these knots are said to be **tied in the bight**)

Loop: A closed section of line, formed when the working end of the rope passes over itself

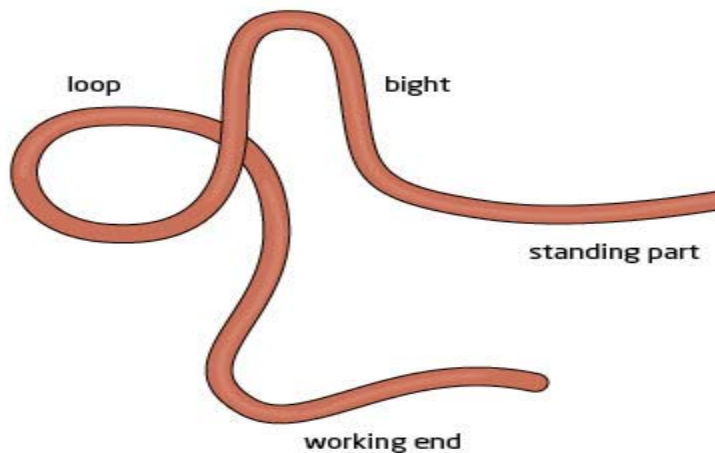

Types of Knots;

Nearly all knots fall into six basic categories, each of which serves a particular purpose:

1. **Stopper knots:** Used to stop a line from passing through a hole or pulley
2. **Bends:** Used to join two separate lines together at their ends
3. **Hitches:** Used to attach a line to a stationary object, such as a hook or post
4. **Loops:** Used to create a closed circle in a line that is of either fixed or adjustable size (variable loops are called slip knots or nooses)
5. **Lashings:** Used to fasten together two solid objects, such as metal poles or wooden branches
6. **Necktie knots:** Used to finish off a formal outfit with a necktie, whether a traditional necktie or a bow tie

Properties of Knots

Every type of knot can be described in relation to the following four attributes or properties:

Strength: All knots weaken rope to some degree, as the twists and turns needed to make a knot weaken the fibers in the cord. Some knots weaken a rope up to 50%, others less. To be safe, it's best to assume that *all* knots will cut the strength of a rope in half. Always make sure the rope you're working with can carry more than twice the load it will need to bear.

Security: Some knots **slip** or **spill** (come apart) when jostled, slicked by water, or subjected to a load. Other knots are more secure and stay intact under even the roughest conditions.

Ease of tying: The easier a knot is to tie, the quicker and more convenient it is to use.

Ease of untying: Some knots **release** (untie) more easily than others. Ease of untying is crucial in situations when a knot must be tied, untied, and then retied (as in sailing, for instance). A knot that's difficult to untie is said to **jam**.

Different jobs demand knots with different attributes. A knot used to tie an anchor to a boat needs to be extremely secure, and since you're unlikely to want to untie the anchor from the line, it doesn't matter much if the knot has a tendency to jam. On the other hand, a hitch used to tie down a load must be secure enough to hold the load temporarily but also easy to untie.

Surgeon's Knot ;

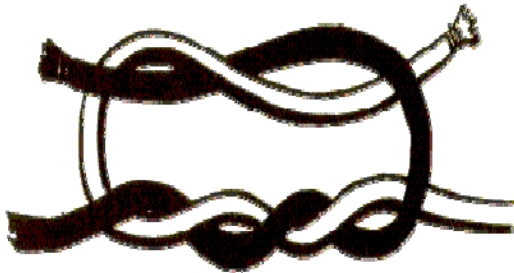

The Surgeon's knot is a Square Knot with an extra twist. The purpose of the extra twist is to give added friction to hold until the second crossing is made.

Clove Hitch;

A hitch used primarily to secure a horizontal bar or pole. It's easy to tie and untie but may spill if the load twists or sways.

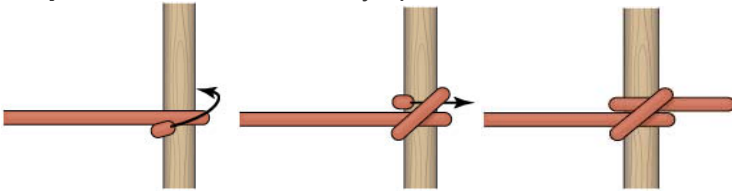

Rolling Hitch;

A hitch used to attach a rope to a pole or larger rope, so that the tension on the rope being attached is parallel to the pole or larger rope. The direction of the pull should be on the same side of the knot as the two initial turns.

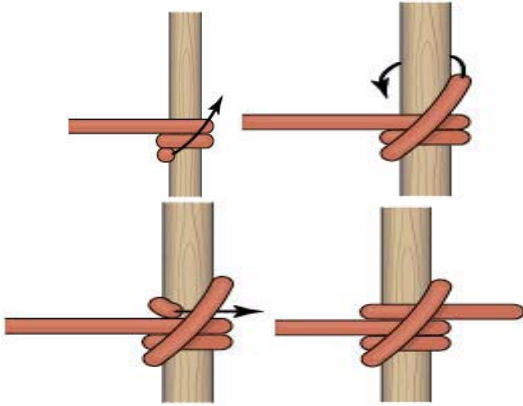

Round Turn and Two Half Hitches;

A hitch used to attach a line to a post or ring. It can be tied even when bearing a load, which makes it good for mooring boats.

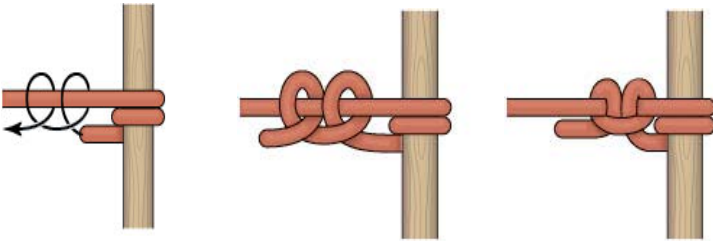

Timber Hitch;

A hitch used for dragging lumber, logs, or any other long objects. It's secure as long as the pull on the rope is steady and consistent—jerky movements tend to loosen it.

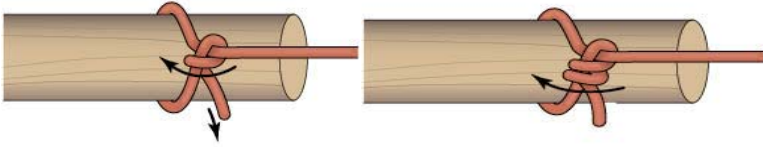

Chain Hitch;

A hitch that can be used to pull any long, solid object. Begin the chain hitch with a *clove hitch*, then add a series of loops at about one-foot intervals along the object.

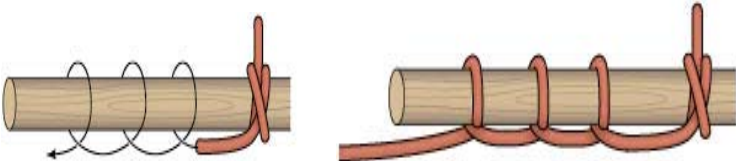

Timber Hitch

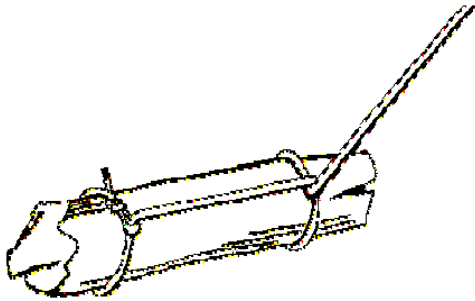

This is an important hitch, especially for dragging a heavy object like a log. It will hold firmly so long as there is a steady pull; slacking and jerking may loosen it. The timber hitch is also useful in pioneering when two timbers are "sprung" together.

When it is used for dragging, a simple hitch should be added near the front end of the object to guide it.

Double Fisherman's Knot;

A bend that can be used to join everything from fishing line to thick rope, as long as the lines being connected are the same widths. In monofilament fishing line, tying the fisherman's knot generates enough heat to weaken the line—wetting the line before tying minimizes this damage.

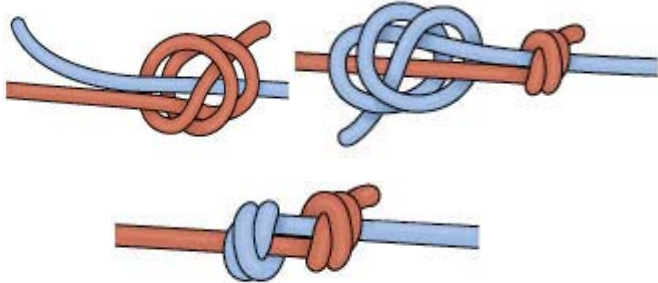

Figure-Eight

Figure-Eight on a bight: you can tie a figure eight in the middle of the rope to make a loop for clipping into an anchor.

Figure 8 on a bight;

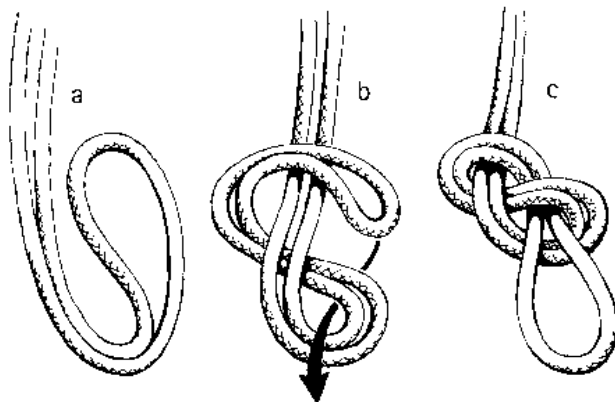
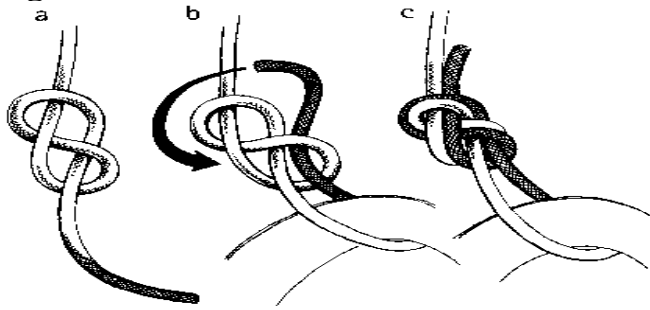

Figure 8 rewoven:



Tying in to a harness with a figure 8 rewoven knot:

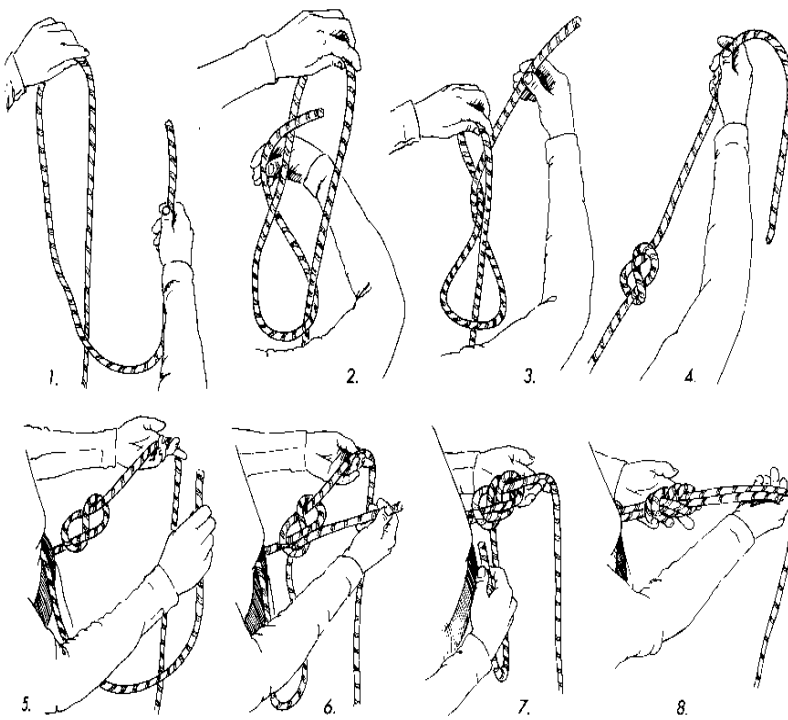
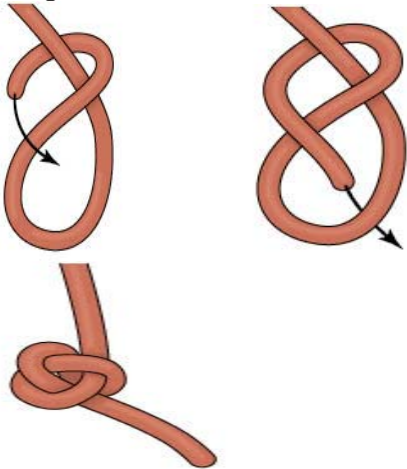

Figure-Eight Knot;

An easy-to-tie stopper knot that's also easy to untie and won't jam. The figure-eight is commonly used in boating, fishing, and climbing, and is the best stopper to use if you'll need to untie the knot quickly at any point. (If safety is an issue, though, the double overhand is a better choice.) The longer the "tail" of the figure-eight knot, the more secure it will be.



Stevedore Knot;

A stopper knot that's both secure and will not jam even under heavy loads. It's also bulkier than the figure-eight knot.

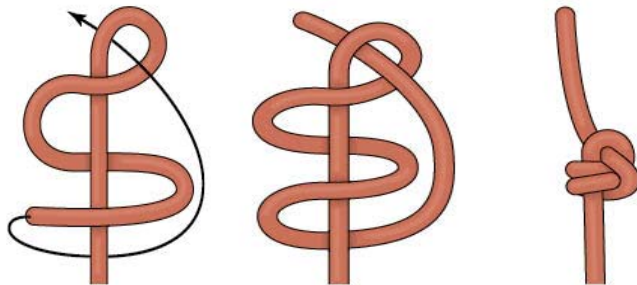

Bowline;

A secure, non-jamming, and very versatile loop used for sailing, rescue, tying down light aircraft, and many other applications. For extra security, tie the tail of the bowline into the loop with a stopper knot.

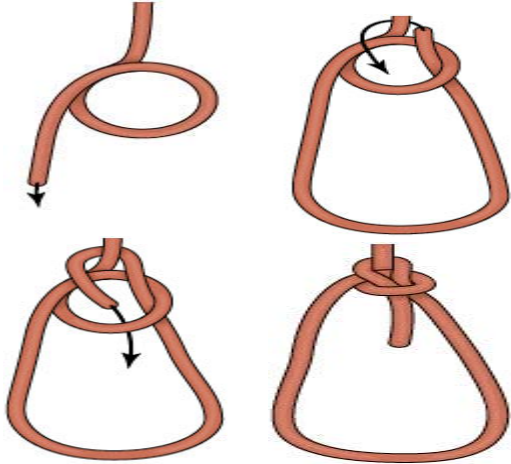

No matter how much stress is put on this strong loop, the bowline can always be untied easily. It's used for attaching canoes to cars, helping people in rescue situations, and suspending food from trees so animals can't reach it.



Make a small loop (the "hole") at one end of the rope, making sure that the shorter end of the rope lies over (rather than under) the longer end.

Bowline on a Bight;

A bowline tied in the bight, which forms a secure and non-jamming double loop. It has many applications, including as a rescue "chair" formed by sliding its two loops over the thighs and torso of a person in danger. It can also serve as a foothold in a rope or be used to tie down a load with a single rope.

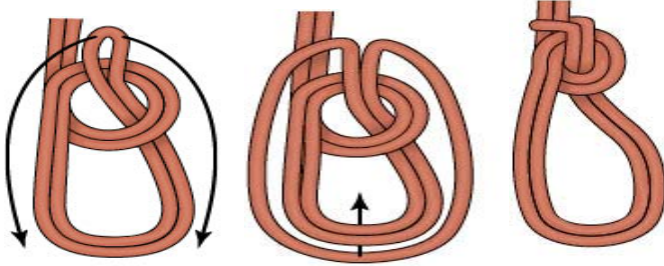

Alpine Butterfly (Lineman's Loop);

A strong, non-jamming knot that creates a loop in the middle of a line. The alpine butterfly can be used to isolate a length of worn rope by tying the knot so that the worn part forms the loop.

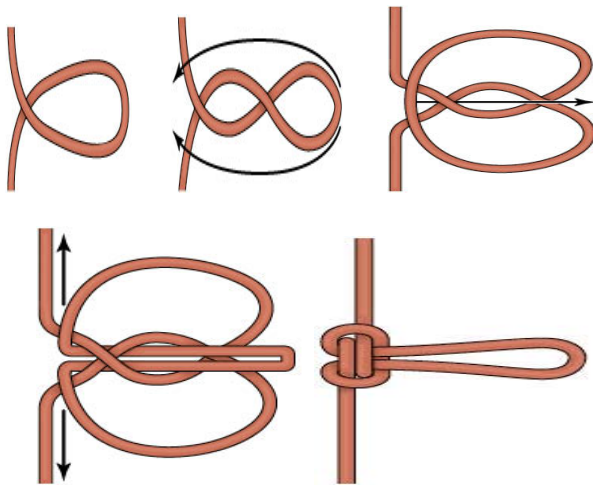

Alpine Butterfly

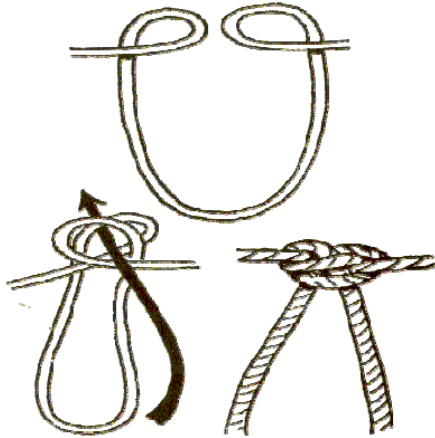

This is the best knot for making a nonslip loop in the bight of a rope. Simply make a bight of the required size with two small overhand loops turned inward at the top. Overlap the loops and bring the bight up and through from front to back. Adjust as necessary.

Man-Harness Knot

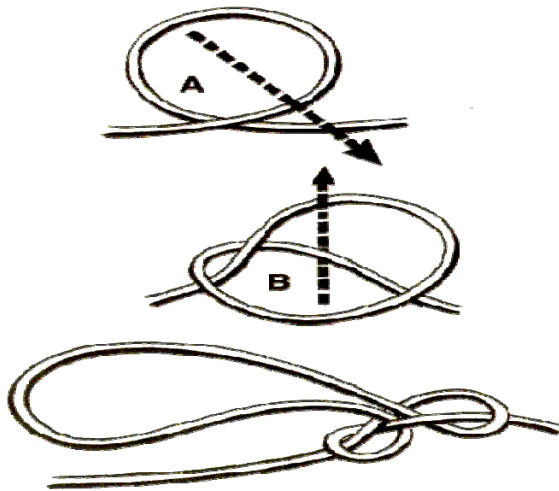

Square Knot (Reef Knot);

A bend commonly used to tie together the two ends of a single line, whether to close packages, hold a bandage in place, tie up furlled sails, or secure something that's unlikely to move much. The square knot is neither secure nor strong: it should never be used as a bend to join two different ropes, or when safety is at all an issue.

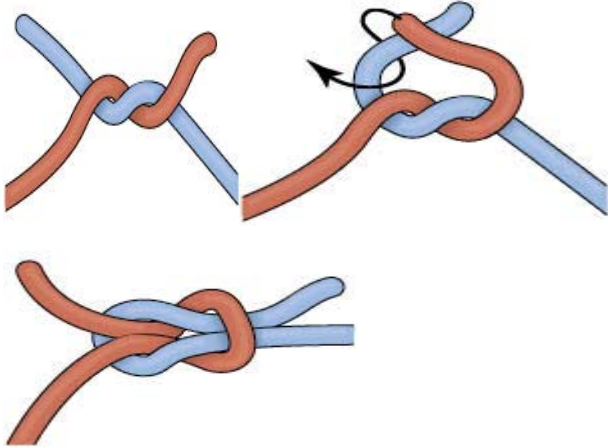

Granny Knot (Thief Knot);

When tying a square knot, it's very important that the working ends of each line in the knot both be *on the same side*, either at the top or the bottom. A square knot that has its two working ends on *opposite sides* is called a **granny knot** or **thief knot** and is not secure or reliable for any task.

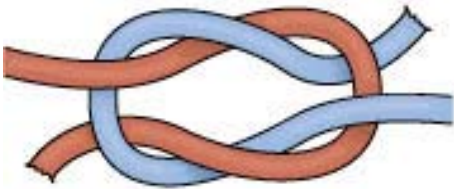

Sheet Bend;

A bend used to combine ropes of different types, such as two ropes of slightly different widths. (If you need to join ropes of *significantly* different widths, use the more secure double sheet bend.) The sheet bend is relatively secure and easy to tie and untie. Make sure to tie this bend so that the tails of each of the ropes are on the same side of the knot.

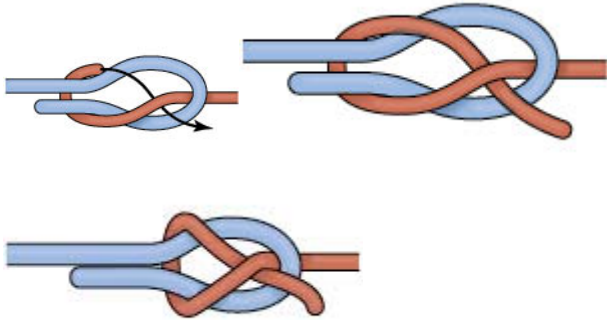

Double Sheet Bend;

A more secure variant of the sheet bend, used to combine ropes of significantly different widths. To tie the double sheet bend, begin just as you would when tying a single sheet bend, then add a second loop.

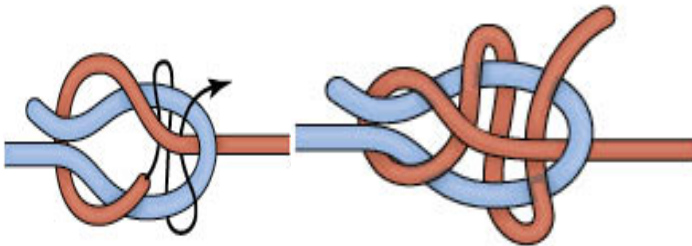

Carrick Bend;

The best bend for joining very thick or stiff ropes, since you don't need to bend the ropes sharply to make the knot. The Carrick bend is secure even when wet, and it won't jam. Make sure to tie the knot so that the tails point diagonally away from each other when it's in "mat" form (step 4, below). The finished knot does not resemble its initial symmetric form at all.

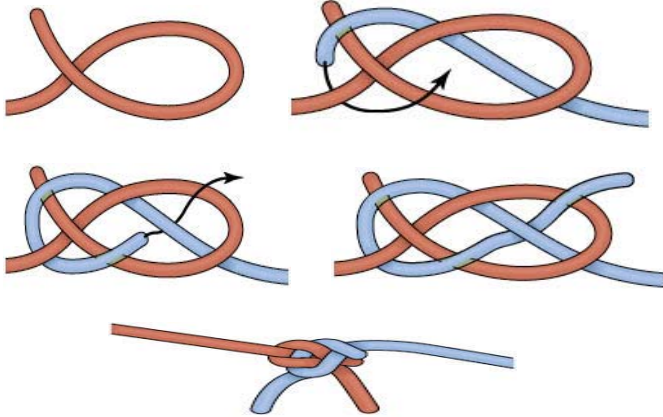

Sheepshank; A bend in which a rope is tied to itself in order to shorten the rope or to isolate a weak or frayed portion of the rope. The sheepshank is tied in the bight (without using the ends of the rope). It will hold together only if subjected to a constant load.

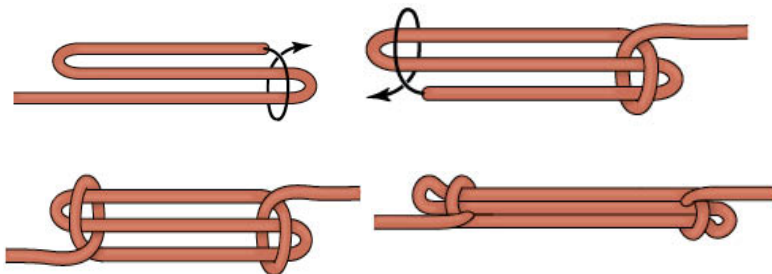

Square Lashing;

A lashing used to fasten together two poles so that they cross at an angle between 45° and 90° and are in direct contact with each other. The square lashing is considered the most secure lashing.

1. Tie a clove hitch on the vertical pole, beneath the horizontal pole.

2. Wrap the working end diagonally across the horizontal pole, twisting the tail of the clove hitch around it as you do. Now wrap behind the vertical pole, down and in front of the horizontal pole, and behind the vertical pole again.

3. Repeat step 2 twice more.

4. Wrap behind the horizontal pole, in front of the vertical pole, behind the horizontal pole again, and then in front of the vertical pole again.

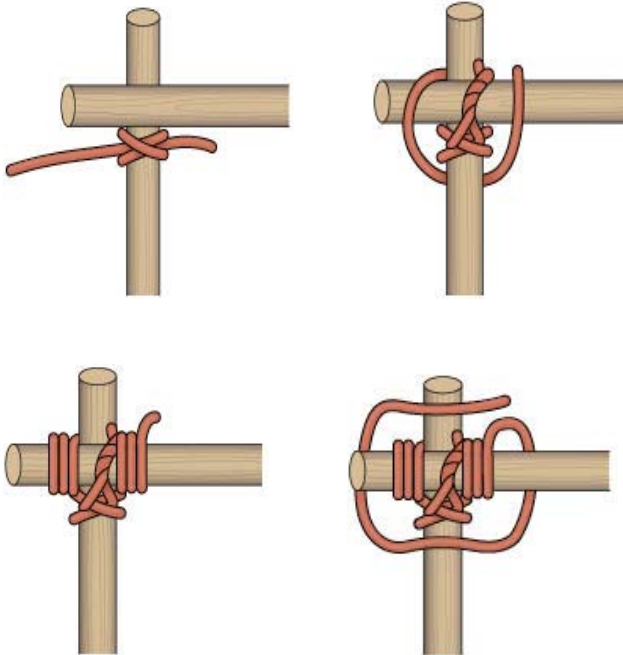

5. Repeat step 4.

Tie a clove hitch on the horizontal pole.

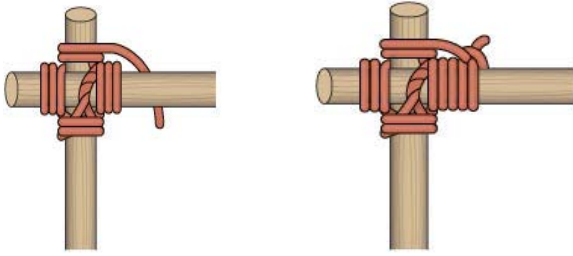

Diagonal Lashing;

A lashing used to fasten together two poles so that they cross at an angle between 45° and 90° but are *not* in direct contact with each other. (If you want the poles to intersect at an angle smaller than 45°, use a shear lashing.)

1. Tie a timber hitch at a diagonal across the two poles.
2. At a diagonal opposite the one used to tie the timber hitch, wrap the working end 3–4 times around both poles.

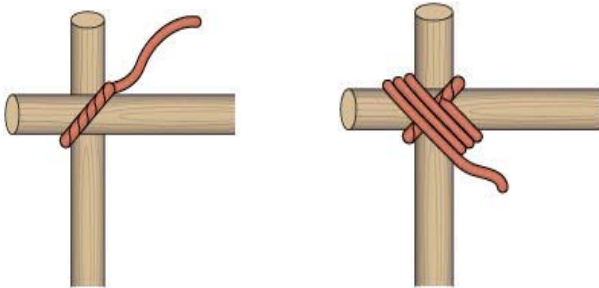

3. On the diagonal parallel to the timber hitch, wrap the working end 3–4 times.
4. Wrap the working end once around the vertical pole.

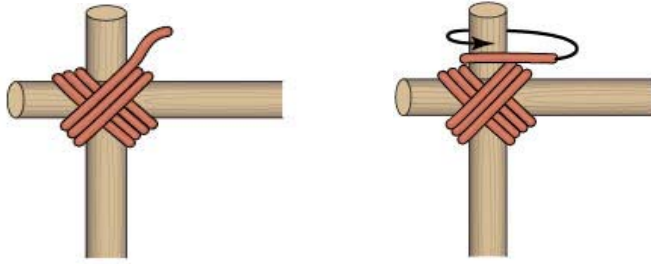

5. Wrap the working end in a circle around the four poles: behind the horizontal pole, in front of the vertical pole, behind the horizontal pole again, and then in front of the vertical pole again.

6. Repeat step

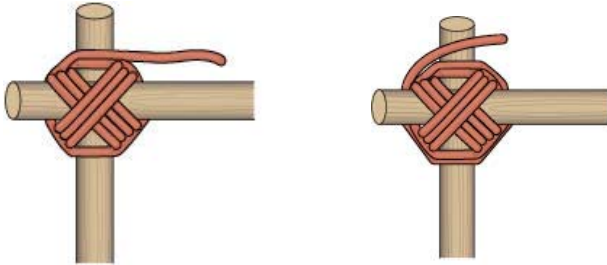

7. Tie a clove hitch around the vertical pole.

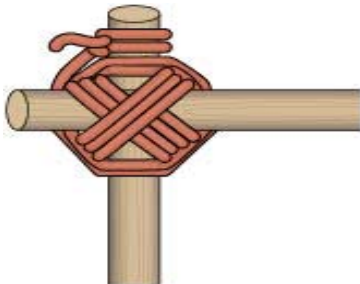

Shear Lashing;

A lashing used to fasten together two adjacent poles. Multiple, tight shear lashings will make the poles parallel, whereas a single shear lashing at the end can allow the poles to pivot and form an "A" shape.

1. Tie a clove hitch around one pole.

2. Twist the tail of the clove end around the working end of the rope, then wrap the rope around the two poles 5-6 times, and finish with the rope snaking up behind the lower pole.

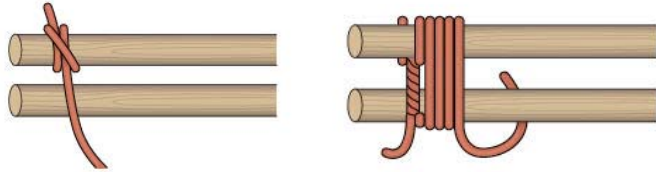

2. Bring the rope between the poles, across the front of the vertical lashings, back behind the lower horizontal pole, and then back up behind the lower horizontal pole on the opposite side.

3. Repeat step 3 twice more.

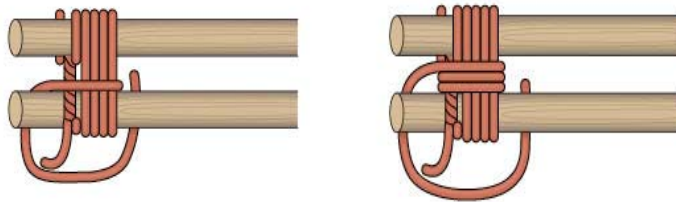

4. Tie a clove hitch onto one of the poles.

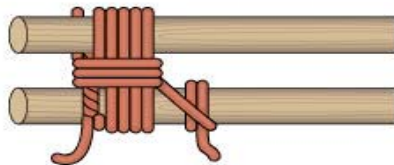

Tripod Lashing ;

This lashing provides a simple and easy way to improvise a tripod with three tree limbs. Lay out the spars (limbs) as indicated. Begin the lash with a Timber or Clove Hitch, make six to eight turns around all three spars and finish-up with two binding turns between each spar. Complete with a Clove hitch on the center bar. The resulting tripod can be used for suspending cooking pots over a fire, making a shelter, hanging a lantern and dozens of other uses.

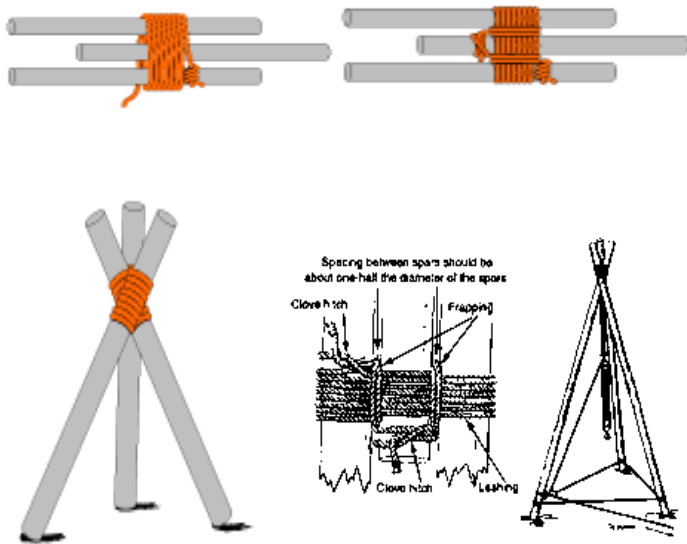

Shear, Tripod, and Square Lashings (start w/clove hitch on one pole, wrap at least

The Timber Hitch

This is a simple, easy to remember knot that is useful for temporarily attaching a line to a tree, post or pole for dragging, raising or lowering. It holds tight only under tension and does not jam. Pay careful attention to the diagram when first learning the knot, as it's easy to form the loop and twists improperly. Use at least three twists, and add more if the object is large or heavy.

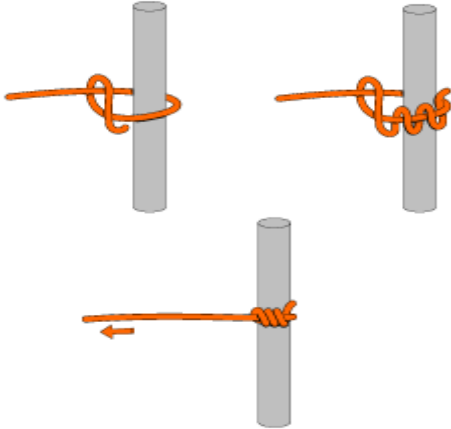

Munter Hitch For safe belaying (much better friction than belay plates or figure 8). Can be used for emergency rappel too, but the rope suffers from twisting

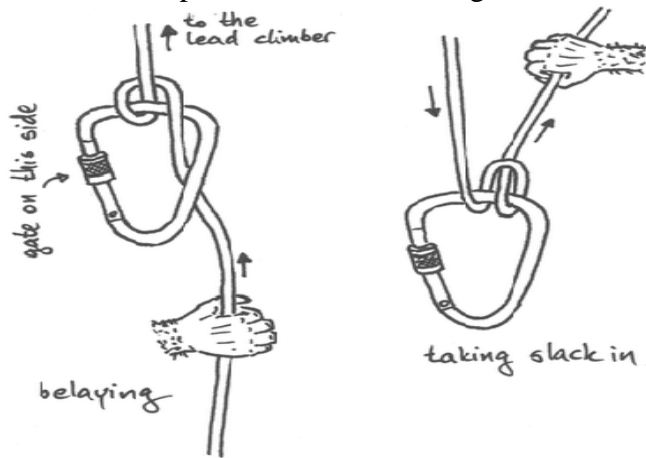

Tautline_Hitch;

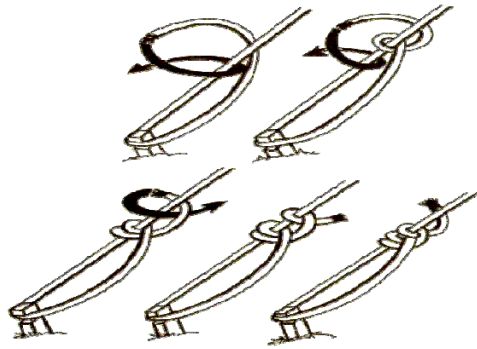

When used for tying a tent guide line, you can tighten or loosen the line by pushing the hitch up or down on the standing part. Pass rope around the peg. Then bring the end under and over the standing part and twice through the loop formed. Again, bring the rope end under, over, and through the loop formed. Tighten the hitch around the standing part.

Butterfly coil:

