

Sharpening Hand Tools



Aaron Moore

2013

When It Comes to Sharpening...

- All hand tools need to be sharpened regularly for good performance. It cannot be avoided and you cannot pay someone else to do it for you.
- Sharpening is simple and anyone can do it. It is only the sea of conflicting information that exists about “the right way to sharpen” that makes sharpening seem difficult.
- If you’ve never enjoyed using a hand plane or chisel, or if you view them as crude compared to what power tools can deliver you’ve probably never used a truly sharp tool.
- A bench grinder does not create a sharp tool.
- “Sharp” is 2 polished surfaces meeting at a 0° radius. Therefore, tools get dull because the cutting edge is rounded over (blunted) or scratches exist (not a polished surface).

What to Consider When Sharpening

- **Bevel Angle:** General term for the angle between the cutting edge and the back of the tool. Usually consists of 2 if not 3 actual angles. Not all tools are sharpened at the same angle, so before you begin to sharpen, decide what angle you are shooting for.
- **Polish of the Cutting Edge:** Finer and finer grit sharpening media hones a finer and finer polish on the tool. All tools need to be honed to a reasonably high finish, but many woodworkers waste a lot of time and money pursuing a ridiculously high polish.
- **Blade Geometry:** Many tools require a straight, square edge (chisels, some plane blades), other benefit from a curved blade (smoothing plane blades and others based on preference).

When these 3 properties are understood, sharpening is simple.

Bevel Angle

- **Primary Bevel:** Main angle the tool is sharpened at. If someone says “this tool is sharpened at 25°” they are typically referring to the primary bevel. This surface is not honed/polished.
- **Secondary/Micro Bevel:** A slightly steeper angle than the primary bevel created at the tip of the tool. This is taken to a high polish.
- **Back Bevel:** Can be used on bevel-down planes, but in general this is not necessary or even desirable. (see next page for example)

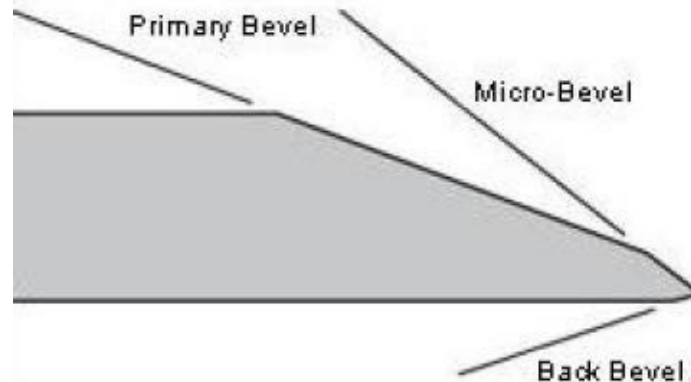

How Bevel Angles Effect the Cut

- **Bevel-Up vs Bevel-Down:** Direction the bevel faces when a tool is cutting wood. Bench planes are bevel-down, block planes are up.
- **Effective Cutting Angle:** Total angle at which the cutting edge is presented to the wood.

BEVEL-DOWN PLANE

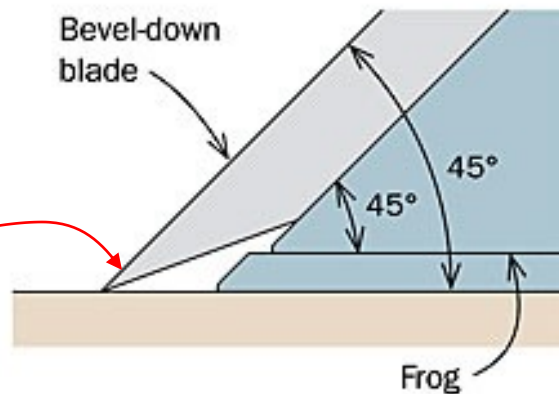

The cutting angle is determined by the frog angle.

BEVEL-UP PLANE

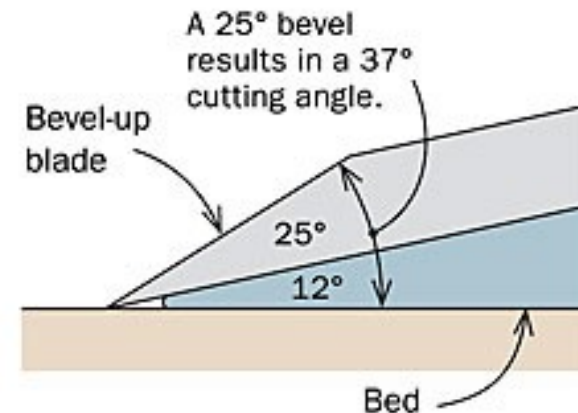

The cutting angle is determined by the bed angle and the bevel angle.

This is where a back-bevel can increase the effective cutting angle on a bevel-down tool, helping to reduce tear out. The other option is to install a high angle frog assembly.

Suggested Bevel Angles

Consistency far outweighs accuracy. If you're within +/- 3° of what is listed below, you will be fine. If you change your angle by +/- 3° every time you sharpen, you will not be fine.

Note that these are the primary bevel angles. When the micro-bevel is added, the actual cutting angle will be ~2°-3° higher.

	primary bevel
Pairing Chisel	20°-25°
General Bench Chisel	25°-30°
Mortise Chisel	30°-35°
Bench Plane Blade	25°-30°
Low Angle Plane Blade	25°

Sharpening Media

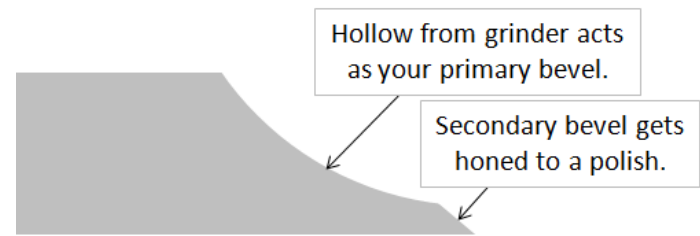

- **Grinders:** Rapid material removal, too rapid for general hand tool sharpening. Grinders are useful for shaping a blade, re-establishing a primary bevel or repairing a chipped blade, much less useful for day-to-day sharpening. If a grinder is to be used, do not grind to the tip. The metal is too thin and will quickly heat up, removing the tool's temper and ruining the steel. Stop grinding a good 1/8" before the edge and cool the tool often during the grinding process. Stopping the grind prior to the edge is not a problem as the grinder is only creating your primary bevel, you will still hone the tip with a micro-bevel so grinding right to the cutting edge is unnecessary.
- **Slow Speed & Wet Grinders:** These are better in the sense that they reduce the likelihood of burning the steel, but they are more expensive and less versatile compared to a standard bench grinder and they will still not deliver a fine edge.* If you are going to use a grinder, learn to properly use a standard grinder and move on. The fewer "specialty" machines you have, the happier you will be.

*Excellent powered sharpening systems do exist, but can be very expensive (\$200 - \$1,000+).

If you sharpen professionally these are worth looking into, otherwise I'd stick to the advice above.

Sharpening Media

- **Sandpaper/lapping paper:** Cheapest initial investment, most expensive long term. For sandpaper, wet/dry should be used, but breaks down very quickly. Lapping film is a more recent innovation and works extremely well and lasts significantly longer than sandpaper, but you will probably have to order it online and costs ~\$3 per sheet.
- **Diamond Stones:** Fairly expensive, “never need to be flattened” and therefore make flatness questionable. I personally avoid these for sharpening flat tools, but they can serve other purposes.
- **Water Stones:** Cost varies, but they are fairly pricey. Excellent results, cut very quickly on all steels, but need frequent flattening. Water is used as lubricant so tools must be oiled after sharpening to avoid corrosion. Course stones need to soak prior to use.
- **Oil Stones:** Cost varies, but they are fairly pricey. Excellent results, cut slowly compared to water stones, but only need occasional flattening, if any. Use oil as lubricant so tools will not corrode. *Note:* oil stones should not be used with A2 tool steel. If you’re using a modern premium tool from Lie-Nielsen, Veritas, etc, buy O1 steel or use water stones. Vintage tools are not a problem.

Specialty Sharpening Media

- **Diamond Paste**: Typically sold in syringes. Only available in fine grits for polishing. Not necessary for most tools, but can be useful for honing curved blades such as carving tools or moulding plane blades.
- **Slip Stones**: Curved sharpening stones available in various profiles and radii for sharpening curved tools.



- **Leather Strip**: Used with some form of abrasive paste. I avoid these for flat tools due to risk of rounding over the cutting edge (loss of 0° radius).



Stop honing here.
 Sharp enough for
 woodworking. _____

Grit Comparison

	Micron Size	Crystolon Stones (silicon cabide)	Arkansas Stones	Diamond Stones	Waterstones	Sandpaper CAMI (USA)	Sandpaper FEPA (Europe)	Other
		India Stones (aluminum oxide)						
Extra Course	270							
	173	Lee Valley Coarse India						
	150							
	141						P100	
	127	Norton Coarse Crystolon					P120	
	116					120		
	97	Norton Coarse India					P150	
	93					150		
	78	Norton Medium Crystolon				180	P180	
	68					Lee Valley 280		
	65			Norton x-coarse diamond			P220	
	66.82				Shapton 220			
	60			DMT x-coarse	Norton 220	220		
	58						P240	
	53.5	Norton Medium India				240		
	52.5						P280	
	50							
	46						P320	
45	Norton Fine Crystolon			DMT coarse				
43				Norton coarse diamond		280		
40.5							P360	
36						320		
35	Norton Fine India		Washita				P400	
29.4					Shapton 500			
29					Lee Valley 600	360		
26.5							P600	
25				DMT fine				
23	Lee Valley Fine India					400		
22	Norton X-fine India		Soft Arkansas	Norton fine diamond			P800	
20					Lee Valley 800			
16					Lee Valley 1,000	600	P1,200	
14.7					Shapton 1,000			
14					Norton 1,000	700		
13		Lee Valley Soft Arkansas			Lee Valley 1,200			
12.6						800	P1,500	
11		Hard White Arkansas		Norton x-fine diamond				
10.3							P2,000	
10		Lee Valley Hard Arkansas						
9.2						1,000		
9				DMT x-fine				
8.4						1,500	P2,500	
7.5					Norton 2,000			
7.35					Shapton 2,000			
7							DMT ceramic stone	
6		Hard Black or Translucent Arkansas				2,000	DMT Dia-paste (6 micron)	
5								
3.63					Shapton 4,000			
3					Norton 4,000		DMT Dia-paste (3 micron)	
2					Lee Valley 4,000			
1.84					Shapton 8,000			
1.2					Norton 8,000		DMT Dia-paste (1 micron)	
1					Lee Valley 8,000			
0.92					Shapton 16,000			
0.5							Green compound	
0.49					Shapton 30,000			

Extra Course

Course

fine Medium

Blade Geometry

- **Straight** : Many tools require straight, square cutting edges (chisels, some plane blades, etc).
- **Cambered (curved)**: Other tools benefit from a slight curve (smoothing plane blades or other plane blades based on preference).



Honing Guides

- For straight or cambered edges on most plane blades and chisels, use a honing guide. You may need a few styles to meet all your needs (skewed blades, for example, cannot go in a side-clamp guide).
- Use a set-up guide to consistently register your tool in the honing guide. Again, repeating an angle exactly is more important than hitting an exact angle.
- Some tools will not fit in a honing guide and must be sharpened by hand (router plane blades, some specialty chisels, etc).



Veritas top clamp

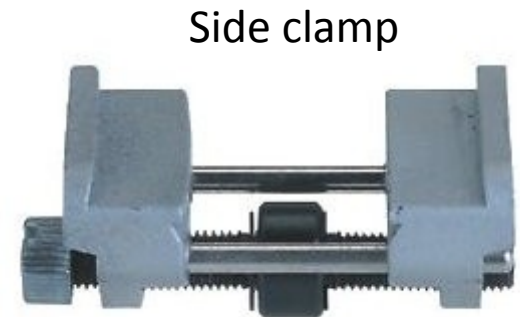

Honing Guides

- **Side clamp**: Cheap (\$15) and effective for most chisels and plane blades. Definitely worth having for the cost.
- **Top clamp**: Not too pricey (\$30-\$45), ideal for skewed blades.
- **Veritas MK.II**: Base cost is \$67, but cambered roller wheel and skew registration jig can be added for extra cost (\$25 & \$30 respectively).
- Dozens more exist all with some pros and cons.
- **Be aware**: Most guides ride on the stone's surface. This ensures parallel contact between the blade and stone, but only allows the use of 1/2 - 2/3 of the stone's surface. Other guides are designed to ride on the sides or behind the sharpening stone. This allows for full-length strokes when sharpening, yielding faster results and more even wear on the stone. However, there is no guarantee that the surface the guide is riding on is parallel to the stone's surface. This can cause heavier abrasion on one side of the blade than the other, skewing the cutting edge.



Setting an Angle

- Angle Setting Jig
- Distance from board's edge to depth stop determines primary bevel angle.
- Adding a 1/8" shim to any stop adds $\sim 2^\circ$ micro-bevel.
- Allows for repeatable, square angles every time you sharpen.

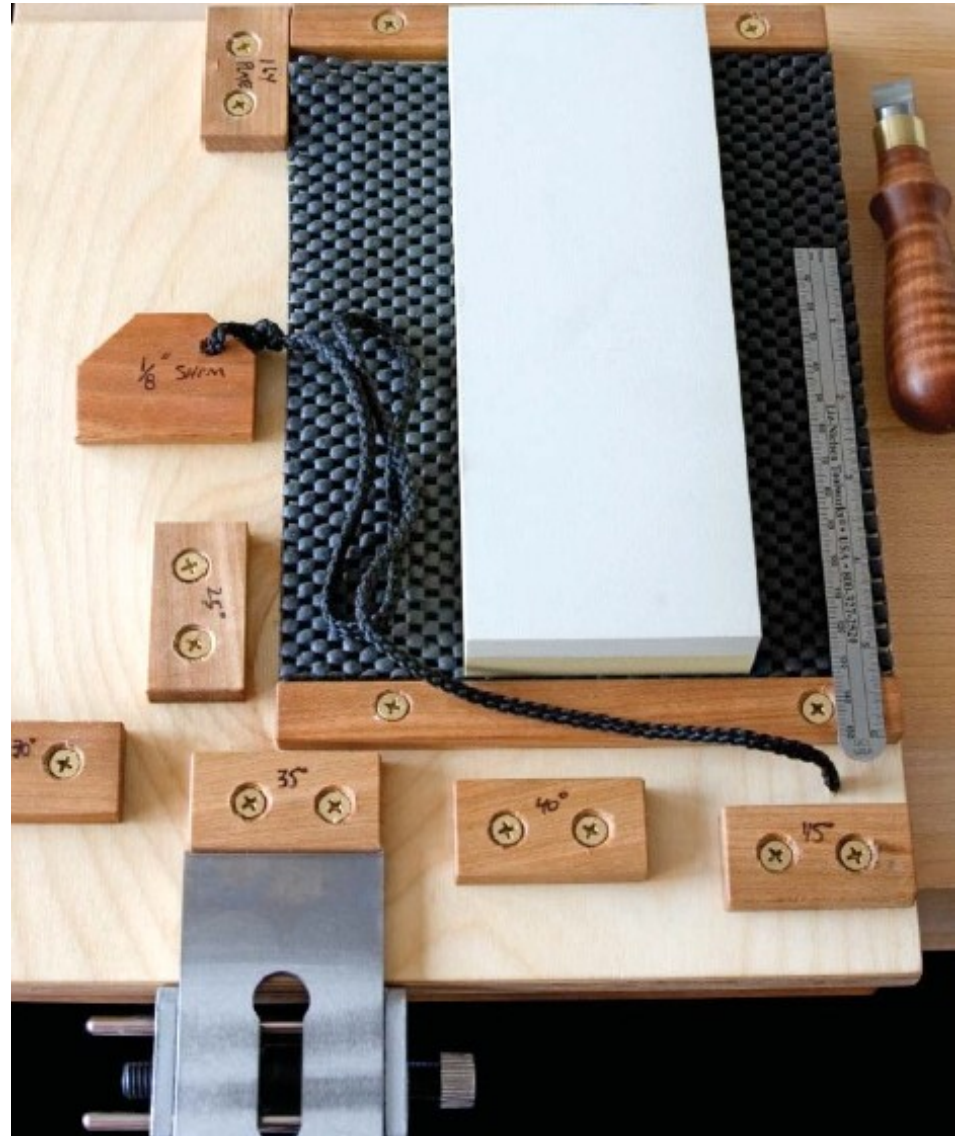

Initial Sharpening

- Start with the back of the tool. Flatten the majority of chisel backs and at least the final inch or more of plane blade backs. Chisels will need to go to medium grit or higher, preferably to a fine grit. Plane blades only need course grit flattening for now (see “ruler trick”).
- Flattening the back should be a one-time chore. After which, you will only need to hone the bevel, so the first time you sharpen a new tool should be the most time consuming and labor-intensive.
- With the back prepared, clamp your tool in a honing guide at the desired angle determined by the angle setting jig.
- Hone the primary bevel on your course grit stone.
- Increase the bevel angle by 2°-3° and hone your micro-bevel on a medium and fine stone or straight to fine if no medium is available.
- Remove wire edge (burr) between grit levels.

Re-Sharpening

- Clamp your tool in a honing guide at the desired angle determined by the angle setting jig and immediately increase the bevel angle by 2° - 3°
- Hone your micro-bevel on a medium and fine stone or straight to fine if no medium is available. You do not need to touch the primary bevel unless your micro-bevel is getting too large (see below).
- Remove wire edge (burr).
- Get back to work.
- Each time the micro-bevel is honed it moves farther up the primary bevel, increasing the amount of material to polish. After several cycles, you should re-sharpen th

Note: one advantage of the hollow created by a grinder is the increased number of polishing cycles you can go through before re-establishing the primary bevel.

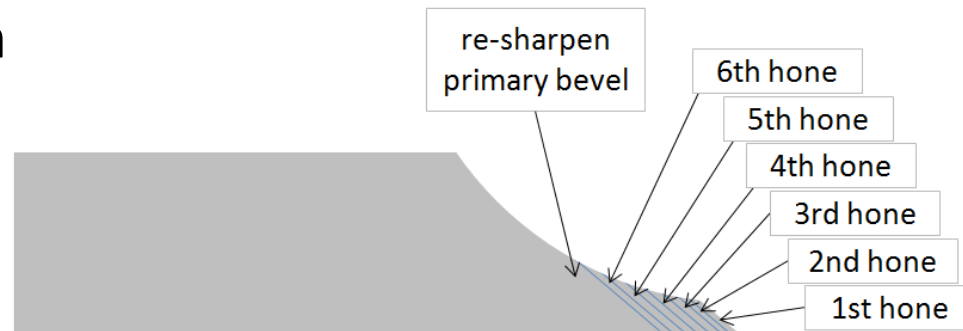

Cambered Edges

- Cambered (pronounced “cam-burr”) edges are desirable on many plane blades, but most necessary on smoothing planes.
- The amount of camber depends on a few factors:
 - The thickness of the shaving. The middle of the blade will project the farthest from the plane sole, a camber then allows the shaving to fade into nothing at the edges. The camber should be just large enough to take the thickest shaving a given tool will require and yet leave no exposed blade at the edges. Too much camber will result in the tool only taking a vary narrow shaving at the desired thickness, too little will result in plane tracks.
 - Angle of the blade. The lower the angle a blade is pitched at, the more curvature it will require to achieve the same effective camber (see formula below).

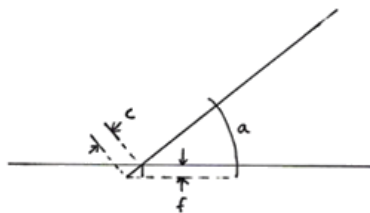

c = observed camber
 f = functional camber
 a = bed angle

$$\sin a \times c = f$$

Notice how the lower the angle, the more camber you need to create to achieve the same functional camber (in this example, 1.5 thousandths of an inch).

F	C	A (deg)	Pitch
0.0015	0.0021	45	standard
0.0015	0.0025	37	low
0.0015	0.0016	65	high



Creating a Cambered Edge

- Large cambers are common for heavy material removal and can be shaped on a grinder. After shaping, the same rules apply for the bevel: do not grind to the tip, polish cutting edge.
- Subtle cambers can be done directly on the stones. One way is to use a honing guide with a cambered roller wheel (Veritas). This allows you to rock the blade slightly creating a radius on the blade.
- When using a side clamp guide, the narrow roller wheel is nice because it doesn't support the edges of wide blades. By using higher finger pressure on the sides of the blade and taking more strokes (vs lighter pressure and fewer strokes on the middle of the blade) you will remove more steel and create a radius.
- If consistency is an issue, try shimming one edge of the tool a few thousandths of an inch, take a few strokes, then shim the other side. This shouldn't be necessary with a little practice, but can help form an even arc early on.

Sharpening Station

- If shop space allows, a sharpening station can be very useful. The more prepared you are to sharpen, the less time it will take and the less you will resist it.
- If you sharpen with water stones, a water source (basement set tub) is ideal. If this is not possible, make sure not to contaminate your fine stones with course particles from cleaning all the stones in the same water bath.



Sharpening Tips

- Clean honing jig wheel and flattening plate before switching grits.
 - Rather than polishing the entire backside of a plane blade, the Ruler Trick (popularized by David Charlesworth) is a method of polishing only the cutting edge of the tool. This must be done at each sharpening session. It does create a tiny back-bevel, but it is essentially negligible.
 - No ruler trick on chisels as the entire back is used to register the tool.
 - Pick a sharpening system (oil stones, water stones, etc) and stick with it, at least until you feel you've mastered it.
- Constantly switching systems or brand names to find “the best” system is unnecessary, expensive, and will only slow your ability to learn proper sharpening.



Resources

DVD: Hand Tool Techniques Part 1: Plane Sharpening *by: David Charlesworth*

DVD: The Last Word On Sharpening *by: Christopher Schwarz*

Book: Taunton's Complete Illustrated Guide to Sharpening *by: Thomas Lie-Nielsen*

Book: The Perfect Edge *by: Ron Hock*

Blog: www.hocktools.wordpress.com *Ron Hock's sharpening blog*

Popular Brands:

*Water Stones**- Shapton, Norton, Lee-Valley, King, Ohishi

Oil Stones- Dan's Whetstone Company

Diamond Stones- DMT

Diamond Paste- DMT Dia-Paste

Lapping Films- 3M and diamond lapping films available at Lee Valley

Angle Setting Jig Instructions: www.lie-nielsen.com/pdf/AngleSettingJig.pdf

**Combination stones do exist and will save some money up front. However, if you plan on sharpening several tools for years to come, individual stones are preferable in my opinion.*