

THE NEWFOUND WOODWORKS, INC.

67 Danforth Brook Road, Bristol, NH 03222

603-744-6872

E-mail: info@newfound.com

Strip Building Notes for Canoes and Rowboats

Revised 10/10



This is a collection of the techniques we have used successfully in building cedar strip/epoxy canoes. We have created this as a supplement to the books we sell. Some of these methods were developed from our own experiences in strip building (learning experiences!), some came from customers' suggestions, others came from the books we provide with kits.

We find the process of strip building is an on-going educational experience. We are constantly updating our tools, techniques, and materials. Often there are several ways to do the same task; the best way for you to do something is the method you are most comfortable with. We are trying to expose you to different techniques and give you enough information so you will be able to complete your project successfully and enjoyably. If some facet of the process is not clear after reading a book like *Canoeecraft*, or *The Illustrated Guide to Wood Strip Canoe Building*, or these Notes please ask us. Email us at <info@newfound.com> or call 603-744-6872 and we will gladly explain further. If you have web access be sure to check out our web page at:

<http://www.newfound.com>

You can also watch us build an Abenaki canoe in the DVD “Cedar Strip Boat Building” and fiberglass a canoe and kayak in the DVD “Applying Fiberglass and Epoxy”. Both can be ordered from our website.

Sometimes it can be helpful to get different opinions on building techniques; although *The Illustrated Guide to Woodstrip Canoe Building* by Susan Van Leuven is recognized as one of the best books on building strip canoes there are other good sources available. This is a very informative hard cover book with clear explanations and color pictures that will help any builder. *Canoeecraft* by Ted Moores is a good reference with more excellent information. Gil Gilpatrick's book *Building a Strip Canoe* (second edition) has a nice practical, no-nonsense take on the building process. If you are building a kayak, *The Strip-Built Sea Kayak* by Nick Schade is a good source of information. Another book on kayak building is *KayakCraft* by Ted Moores; he describes stapleless construction techniques. Even if you are building a canoe the kayak books will be useful references. Mac McCarthy, author of *Featherweight Boatbuilding*, has some different techniques and his enthusiasm will boost your confidence that you too, can build a boat. The above books are available through Newfound Woodworks. A trip to your local bookstore may turn up some others such as David Hazen's *The Stripper's Guide to Canoe-building* and *Rip, Strip, Row* by J. D. Brown.

A Brief Outline of Strip-Building:

Strip-built, or cedar-strip, or cedar-strip/epoxy or wood-strip all refer to the same technique for building a boat. Briefly, thin strips of wood are edge-glued together around temporary forms, the strips are then covered inside and out with fiberglass. The resulting boat is lightweight and rugged. It does not have any ribs and is easy to maintain. While the method is generally considered too time consuming for mass-production, it is an ideal method for the do-it-yourselfer to make one to several boats.

The quarter inch thick strips of cedar are encapsulated in fiberglass and epoxy. This makes a stiff, strong and rugged skin that can take a lot of abuse. The fiberglass protects the wood from water so the upkeep of the finished boat is low. A new coat of varnish every year or two keeps the boat looking good and provides UV protection.

No steaming is necessary to build the boat. The strips are thin and flexible enough that almost any shape boat can be constructed. In fact many of the commercially available canoes and kayaks started their life as strip built boats. A designer will build a stripper to create a prototype of the design for testing. If he likes the design, a mold of the boat is made, and fiberglass boats are made on this mold.



A Rangeley Lake Boat ready to be taken off the forms

Here is an outline of the process:

1. Create cross-sectional forms of the design,
2. Mount the forms on a strongback,
3. Edge-gluе between the strips with carpenters glue,
4. Staple strips to the forms,
5. Pull out the staples,
6. Plane the wood fair,
7. Sand the wood smooth,
8. Lay fiberglass over the wood,
9. Brush epoxy resin onto the fiberglass to make it clear and bond it to the wood,
10. Install a keel (optional)
11. Sand the outside smooth,
12. Remove the boat from the forms,
13. Sand, fair, smooth the inside,
14. Lay in fiberglass and epoxy,
15. Install gunwales and decks for canoes
16. Varnish,
17. Install seats, and whatever outfitting is needed for the type of boat you are making.
18. Put the boat in the water.



This is a fun and gratifying project. Anyone who is mildly handy should be able to successfully finish a canoe in 120 to 150 hours (if building from a kit). A strip kayak generally takes a little longer at 150 to 200 hours (a Hybrid takes about 120 hours). The skills required are minimal, and if you get a kit, you don't need many tools and you will save many hours. In addition, with a kit you will get top quality materials that may be hard to acquire for the neophyte.

Tools:

Below are some tools that work well and we can supply. Other tools you'll need are a shop vacuum, respirator with organic vapor and dust filters, random orbit sander (Porter Cable Model 333), Arrow T-50 stapler and lots of clamps. You should have some spring clamps, some quick clamps and some c-clamps.



Japanese Wood Rasp



Japanese Pull Saw



Block Plane



Pro-Prep Scraper



Spokeshave



Fairing Board

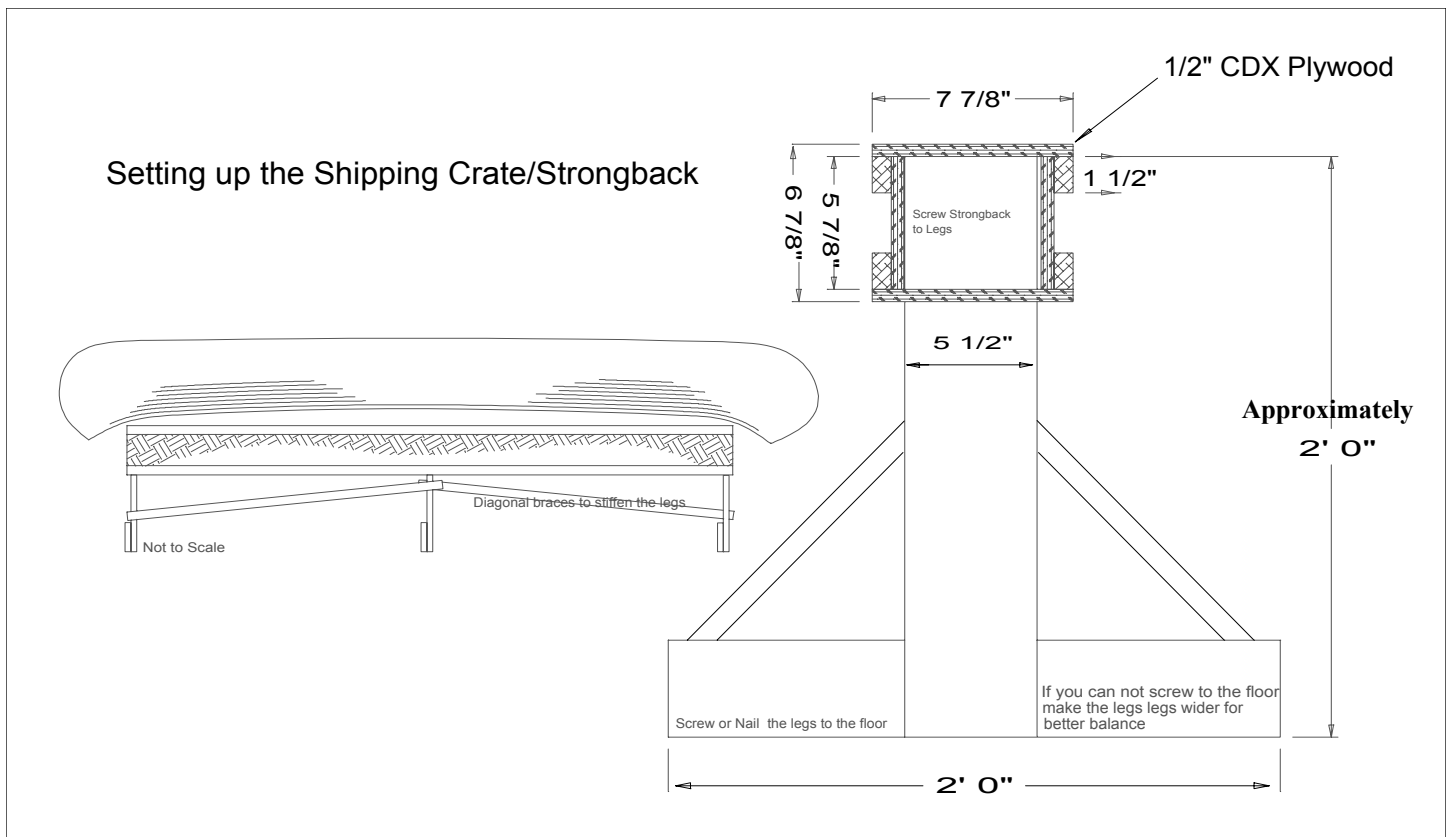

Strongback:

When we ship a canoe kit by truck, we can make a crate that is about 8" wide x 7" high x 19' long. This crate can be made into a strongback fairly easily. Or we can simply package the strips and rails in cardboard and you can make your strongback to the dimensions shown above or use one of the methods described in Susan Van Leuven's book, *"The Illustrated Guide to Wood Strip Canoe Building"*.

First, you need to remove the cover and remove all the parts from the box. Cut the box off shorter than your canoe length so the stem forms can hang off the ends of the strongback. On page one of your canoe plans you should find a strongback length indicated. Or you can figure out the exact length for your particular canoe design by drawing the layout lines on the strongback (even temporarily). Reinstall the end cap you had to cut off or make a new one. Cut three 26-30" "legs" from a 2" x 6" x 8' board; insert one in each end of the box and one in the middle. The size of these legs is dependant on what you want for working height. Cut 4-1/2" off the length of the box covers and reinstall so that you have spaces for the legs at each end and in the center. Use sheetrock screws through the side of the box to secure the legs. Flip the new strongback onto its "legs" and you can make "feet" by attaching 2 x 6 x 24" boards to the legs. See the diagram. If you didn't get the shipping crate with your kit you can make one by following the diagram above.

The following method of setting up the forms is described in detail in our "Cedar Strip Building" DVD.

Sight down the length of the strongback, or use a good carpenter's level) to make sure it is straight and level, both in length and side to side. Use shims under the feet where necessary. Fasten the feet to the floor in some manner and install cross braces between the legs.

- ⊗ Ensuring the strongback is straight and level now is very important for later steps and will help avoid problems is setting up the forms.

Use a monofilament line to create a line down the center of the box. This will be your centerline for locating your stations. Find the center of the length of the box. Station "0" will go there and all other station locations

will be taken from there. If this is a Rangeley, Wherry, or Whitehall, find the widest station and think of that as the “0” station in this description.

Keep in mind that for some canoe designs the stem forms will have to be removable from under the canoe because the form will be captured by the finished canoe stems. You need to provide for this when you are fastening the stem forms to the strongback.

Set up mold forms:

Setting up the forms will vary with the different boats. Refer to your plans for detailed drawings. There is a good graphic diagram in the appendix of these notes.



Usually the forms will be located 12" apart on the strongback. It's critical you take the time to accurately measure and set up the forms to avoid problems later.

Draw a line on the vertical center of the forms using the form plans. This line is critical to the accuracy of the forms layout. If we supplied the forms, you will find the vertical center lines already scribed.

Mount a 1-1/2" x 8-12" block flush to the base of each form on the side opposite the centerline. The form that the stem form attaches to has its block on the stem side and the stem form

needs to be notched to get around it. The forms are then attached to the strongback with screws through the blocks. Start with form 0, or the widest form, centered on the middle line of the strongback. The remainder of the forms are mounted with the measured line on the center side of the form (see your plan sheet). Ensure they are plumb and square to the lines.

The stem form attaches to the center of the last station form. Attach blocking, approximately 1-1/2" wide x 4" long on the end of the strongback in such a manner that the stem form can be supported on the centerline. Attach the stem form to the center of the form with a cleat and screws.

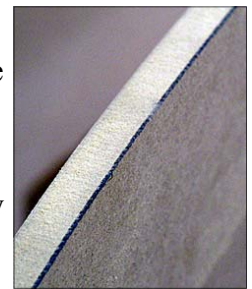

Mark the “true” edge of the forms

Using a strip as a batten along the forms, check the forms for fairness and adjust forms as necessary. We also use a monofilament line from bow to stern to line up the form centerlines. Attach a batten to each form near the keel line starting at a stem to form a rigid frame for the strips. Some designs have very wide stations and may need additional battens attached “underneath” the hull lines (below the sheerline) to stiffen them up.

Bevel the outer edges of the forms with a block plane or spokeshave so a strip will lay flat against it from form to form. Be sure not to bevel the edge on the same side as the measured line on the strongback, this is the true shape of the hull. We like to mark that edge with a pencil to avoid removing any material on that edge. Most of the beveling will occur near the sheerline and the stems.

Laminating Canoe Stems:

In your kit you will find the materials to make laminated stems for your canoe. The wood is cut into pieces measuring 3/16" x 7/8" x 4'. There should be 8-10 pieces of ash for the inner stems and 8-10 pieces of ash for the outer stems. You will use half of each stack for each end of the boat. When glued together the 4-5 inner-stem pieces and the 4-5 outer-stem pieces should each stack up to about 3/4". We cut the ash thinner to make it easier to bend, depending on what design you are building and the nature of the bend. You should not need to do any steaming to make your stems, except for certain designs where there is a severe bend in one spot. In such a case you could wrap a towel saturated with really hot water around just the severe bend area before try-

ing to bend. Then you will have to clamp it up and let it sit and dry out for a day or so before you can apply epoxy. Or, use a heat gun directed at the area of sharpest bend.

You can assemble your stems directly on the canoe forms. Set up your forms and make sure they are all securely attached to the strongback, or you can laminate them over the stem forms clamped to workbench or other solid surface. You do not want the forms to move while you are trying to bend the stems. Both the inner and outer stems will be bent at the same time. Also make sure the epoxy will not stick to the forms by covering the edges with duct tape.

Sort Your Laminations:

Sort through the laminations looking for the best pieces. You want the best looking pieces to show. On the inner-stem, the innermost lamination will be visible and on the outer-stem, the outermost will show. Decide which end is the best and plan to put this end at the bottom (keel) of the stem. The top (gunwale) end will be cut off eventually.

Dry Fit:

Dry fit the pieces to get a feel for how they bend and to make sure everything goes together correctly. Line up the ends of the strips and place the stack on the forms with the end flush against the sectional form at the end of the stem form. Use a clamp to hold the strips in place using the clamping hole closest to this end. Slowly bend the strips down around by adding a clamp to each hole. Press down with your hands on the stack close to where you are clamping. Don't grab the far end of the bundle and try to bend the whole thing at once. Do your bending slowly and incrementally clamping as you go until the stem is bent completely.

Remove the clamps and with the stack in the same order, mark a "V" on the side so you will be able to get the stack back in the same order.

If you are making one of the modern canoe designs such as the Freedom, Winisk or Kipawa with a sharp bend at the foot of the stem, you may have to apply a towel with hot water at the sharp part of the bend. This softens the wood and reduces the chance of cracking. Leave the laminations clamped in place until they are dry. Or use dry heat from a paint removal heat gun during the actual gluing and bending step.

Mixing the Glue:

Get all your tools ready to go so you don't have to search for them while your epoxy is starting to cure. You will need clamps, gloves, measuring cup, stirring stick, and acid brushes or squeegee. Spread out the stem laminations next to each other with minimum gaps between. Hold out the outer most lamination of each of the inner and outer stems. These do not need glue on them. The laminations to be glued should be on newspaper, plastic or cardboard, or some other surface that you don't mind getting messy with epoxy. Pump two strokes each of the resin and catalyst and stir it thoroughly. Mix in Cell-O-Fill or colloidal silica until the epoxy is



Jim and Jeremiah bending ash stems around the stem forms. They have spread thickened epoxy between laminations and separated the inner and outer stems with a piece of plastic.

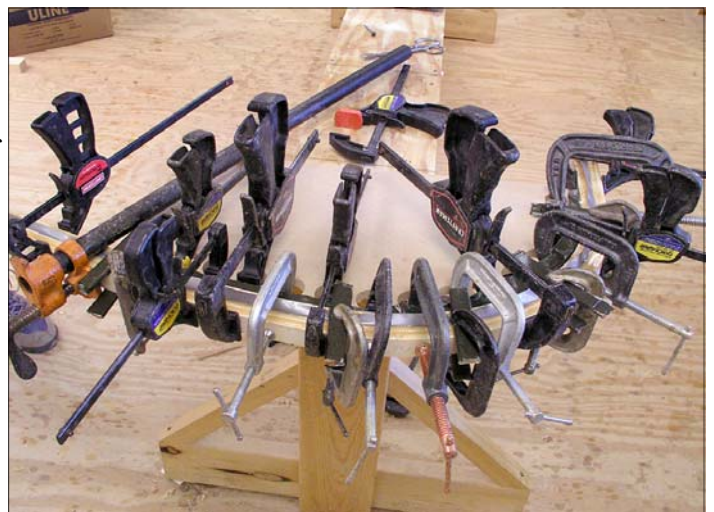

These laminations are done before attaching the form to the strongback but they could have been done with the forms right in place on the strongback.

about the consistency of thick molasses. Start with an ounce of Cell-O-Fill and stir it in. Add more in small amounts until you achieve the desired thickness.

An option here would be to use **SilverTip Gel Magic**. This is a two part, epoxy laminating system that will not sag when mixed and doesn't require a thickener.

Spreading the Glue:

A fast way to spread the epoxy on your laminations is to put it into a sandwich bag and cut one corner. Then you can spread it like you are decorating a cake (ask the baker in the family if you aren't sure about this).

Use a brush or squeegee to spread a 1/16" layer of the thickened epoxy onto the laminations. Mix up more epoxy as required. Stack up the inner laminations back in their original order with the outermost (unglued) strip on top. Lay wax paper on top of this and then stack the outer stem laminations on top of the wax paper. Hold the bundle of strips so the ends and sides are lined up and repeat the process you did with the dry fit.

- ⊗ As you are doing this process keep in mind that it is better to mix small batches and have to re-mix than to mix a large batch and have it seize up prematurely. Also, get the epoxy squeezed out onto the laminations and then you will have more time to spread it.

Bending the Stems:

Be sure to keep the sides of the laminations aligned, centered on the stem form. After the strips are completely clamped in place, clean up the squeezed out resin with a squeegee or brush. Removing all the drips now will make your life easier later.

Let the epoxy cure for a day or so until the resin is hard. After the glue has hardened remove the clamps and pull the stems off the forms. The inner and outer stems will separate at the wax paper. It is now time to clean them up.

- ⊗ You MUST NOT remove the stems from the forms prematurely. Epoxy takes 24 to 48 hours to reach a "final" cure. Until it has reached this state, your stems may delaminate if you remove the clamps too soon.
- ⊗ In a hurry? Warm up the stems by placing clamp lights near them. This is called "Post Curing". The heat causes the epoxy to come to a cure sooner.

Clean Up:

Use a block plane to remove all the glue and irregularities from one side of the stems. Make a nice, even, flat surface on one side. Flip the stems over and repeat on the other side. Plane this side down so that the inner stems are about 5/8" thick and the outers are 13/16". Make sure that the thickness is consistent along the whole length of the stems. Different designs will require different widths for the inner stem (the Wee Lassie stem needs to be about 1/2" wide at the base to accommodate the slender entry).

- ⊗ Before returning the inner stems to the forms in preparation to building, round over what will be the bottom end that you will see inside when the boat is complete. This will be your last chance to easily make this end look good. Use a couple of pieces of tape to secure the inner stem to the forms. Be sure to remove this tape before stripping over them.



Beveling:

It's now time to bevel the inner stem so strips coming along the side lay flush against the side of the stem. The outer edge of the inner stem should end up being about 1/4" wide. Note it is important the inside stem with the strips attached to each side should measure about 3/4" wide so when you attach the outside stem (3/4") the cedar strips can be faired to it. Mark the center of the stem and the two final edges clearly before starting. Lay strips along the forms to use as guides. Use a spoke shave or block plane to do the beveling. A block plane is easier to control because it won't take as much material and doesn't require a long learning curve.

Some designs need the inner stem narrowed down to 1/2" for the strips to run fair and flat. Use a test strip to check.

You do not need to bevel all the way up initially. Instead, get the bevel right on the vertical part of the stem, from the sheer up to approximately the waterline. You can strip up close to this point before doing the final bevel on the rest of the stem. Sometimes it helps to wait to do the final shaping near the bottom of the canoe until you get to that area so you can see exactly how the strips are going to come into the stem.

- ⊗ As you proceed you will have to be very careful that you don't strip up along the inner stem too far before you do the proper beveling and you don't have any room to work. The tendency is to forget about the inner stem in your enthusiasm.

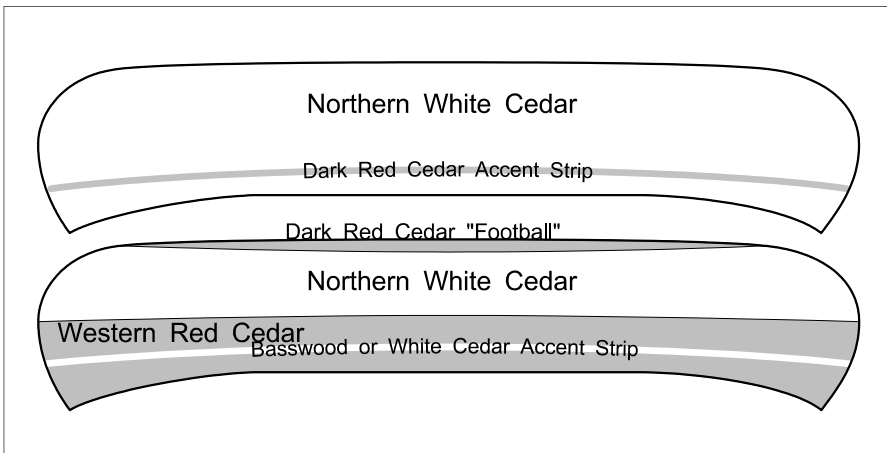

- ⊗ Row boats have a more obtuse angle, so the inner stem should be kept as wide as possible, probably 7/8" - 1".

Stripping:

The kits come with a selection of wood. You will need to decide how you want to use it. There is no structural reason for using any particular wood in any particular place. The main determination of strip placement is purely aesthetic. The accent

strips usually look best about three or four strips down from the sheerline. We like the looks of a dark upper with a light accent running down through it. Two to four strips of dark, then the accent and then several more dark works out well, make sure you have enough strips left to finish the sheerline by the stems. A dark football patch always looks good as well.

Don't let us determine for you what looks good, it is a personal choice. These are just recommendations. You will be well served by taking a look at your wood before you start, inventory what you have and what it looks like, and use the information to help you decide how you are going to use your strips. Wood is a natural product and has naturally occurring variations in coloring and grain. Time spent thinking about your stripping pattern before you start will help make a better looking boat.

- ⊗ We have stripped most of our canoes with the bead side up. This allows you to pull the strip down by hand without the use of the "sacrificial strip" that you would need if you stripped with the cove side up. The drawback is that you must be careful not to staple too close to the bead as it will make the next strip difficult to pull down tightly.

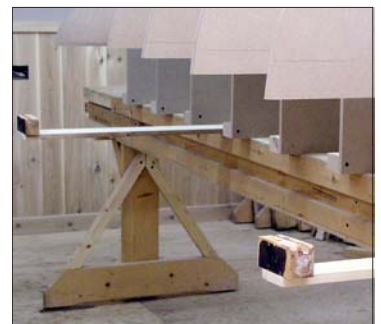

This shows the Outriggers" we use to hold the strip while applying glue.

If you strip with the cove edge up, cut some short (6") sacrificial hand pulls. Cut off the cove on these strips with a plane so they are easier on your hand. The drawback to this method is that it will be difficult to insert glue into the cove when you get to the bottom of the canoe and the strips are laying down flat.

You can apply glue to the strip by holding it in your hand and running the glue nozzle down the cove to deposit a THIN stripe of glue. We use a couple of pieces of 1x stock fastened to the strongback with a 1/4" slot at the end to hold our strip with the cove side up for glue dispersion. If the glue dribbles out of the cove as you are trying to position it on the previous course, then you may have too much glue.

- ⊗ Remember, any glue that squeezes out should be wiped off with a damp cloth both inside and outside to minimize sanding later.

We use carpenter's wood glue to glue the strips together. Either Elmer's ProBond or Titebond. We are currently using Titebond III. We don't use epoxy in this situation because of the pot life and clean-up. Waterproof glue is not required.



Glue the football strips while stripping up the sides

The epoxy and fiberglass on the outside is all the waterproofing required. Because of this it is easier and safer to use the simple carpenters glue. It is plenty strong enough.

Usually an Arrow staple gun with "Ceiltile" (9/16" or 13mm) staples works very nicely. A manual gun seems to drive the staple until the crown stands just proud of the cedar strip—a good thing. An electric or air stapler should be shimmed in order that the crown doesn't penetrate the cedar. Watch out for staples that rust; they will leave stains in the wood as you use the damp rag to remove excess glue.

The first strip will be the sheerline strip. The extra time spent getting this strip "right" will make the rest of the stripping more pleasant. Ensure it is a fair curve by sighting down its length from the bow and stern and adjust as necessary. It is not absolutely critical it lines up exactly with the sheerline on the forms, the important thing is it produces a smooth fair line that is pleasing to the eye. Any bumps or dips will be magnified in later strips. Also ensure the strips are even with each other on both sides of the

hull.

When your stripping progresses to the bottom of the stem, you might want to consider alternating the strips in a "herringbone" pattern as you proceed to strip the "football" section. The procedure is not as difficult as the end result looks, the strips can be easily cut to the proper angle with a small saw or utility knife, and the design seems to lend strength to the bottom of the canoe.

To install the final strips in the "football", glue up a section of 6-8 strips starting with two strips about 8' long in the center, then two 6', then two 5' and so on. You can glue this football "patch" together right where it is going to go, but BEFORE you strip up to it with the rest of the strips. Once the glue has dried, remove it from the forms and put it aside till you need it. Rip the cove or bead off the final strips before the football so that you have a square edge to fit the football against. Have someone hold the glued up football over the final open section while you mark a cut line in pencil from below. Cut to shape, fit in, and glue this one up with epoxy resin mixed with Cab-o-sil and wood dust (this concoction is explained in the epoxy section).



Sight down the sheerline strip from the bow or stern to ensure it's fair.

Add the Outer Stem:

Pull the staples carefully, so that you don't dent the cedar (Use a good pair of pliers and pull straight out). Now is the time to block plane or spoke shave the excess strip material at the stems to make a continuous curved base for attachment of the outside stem. We attach the outside stems with epoxy, using screws and washers in pre-drilled holes every 4-5" to achieve a tight line of epoxy between inside and outside stems. Wax the screws before you attach the outer stem. The outside stems should be shaped from 3/4" at the base to about 7/16" before mounting on the canoe. This 7/16" width allows a small edge on either side of the 3/8" brass stem band later. Apply quick release tape to the hull along the stem line on both sides to prevent epoxy from staining the adjacent strips.

When the epoxy has cured sufficiently, remove the screws and plug the holes with pieces of a dowel and thickened epoxy. When cured, cut/shape them flush with the stem. Finish shaping the stem to blend in smooth and fair with the hull. If you are not going to use a stem band, round over the edges of the stem with sandpaper.



The outside stem on a Rangeley Lake Boat

Fairing/Sanding:

Sanding a stripper can be time consuming, but there are things you can do to make it go faster. The best way is to only do as much sanding as is necessary. When fairing the strips the goal is to make a smooth surface which is also ready to accept epoxy. First remove any big drips of glue with a scraper. A Pro-Prep works well for this or any paint scraper. A scraper works best if it is sharp. Keep a fine metal file handy to touch up the blade as it gets dull. Scraping the glue is usually not enough to dull it, but you want the tool sharp to begin with. After the major drips are gone, sweep or vacuum the surface to get rid of the loose bits of glue.

Next, plane the surface with a sharp block plane or spoke shave. You want to remove the major irregularities in the surface. The ridge between two strips should be smoothed out and any steps at butt-joints should be knocked off. Don't be afraid of using the plane. With the plane set very fine you will have much more control than you would doing this task by sanding. You can easily remove just the wood you want if your plane is good and sharp. Remember, the goal now is fairing, this means you want to create long, smooth curves without any sudden bumps or dips. To do this, use long strokes with the plane. Do not concentrate on one place. If there is a low spot, you will have to lower the area all around it so there is a smooth transition. High spots should be knocked off with a few short strokes of the plane then smoothed out with increasingly longer ones. The plane can be used diagonally to the grain as well as with it. For best results, hold the plane approximately parallel to the grain while pushing it diagonally across the grain.

When most of the major irregularities are removed, it is time for the fairing sander. To save yourself time, start with a very course sandpaper. 40 or 60 grit will do well. This stuff can remove wood pretty quickly so you need to use some care. It will also create deep scratches in the wood, so **always sand with the grain**. The fairing sander does not work well on inside curves. Instead use a foam or wood block cut with a curved face to get into these areas. Again, the goal is fairing, don't try to make one small spot perfect. This can make a low spot. If you are trying to smooth out an area that is low, you want to transition the areas around it to make a fair surface down to the low spot. This requires that you sand with long strokes. Use your whole body and don't be afraid to lean into it. If the sand paper gets dull, replace it. Don't waste your time sanding with dull paper just to save the few cents of a new sheet. Sharp paper works faster and does a better job.

You are done with the fairing board or curved sanding block when you no longer see any glue on the surface of the wood and there are no visible signs of saw marks on the strips. Now you can go to a random orbital sander. A good place to start is 80 grit sandpaper but you may be able to use coarser. The goal now is to remove the surface scratches left by the fairing. You want to make the surface of the wood uniformly smooth. Once again, the boat should be fair, so don't concentrate in one spot. Work in two foot wide swaths from centerline down to the sheerline, then move over one foot so you overlap half of the section you just did. Move

A Note about Bias Cut Cloth:

Some of our current kits are supplied with two extra yards of fiberglass cloth so that you can cut your own tape on a **BIAS**. We believe that this is a better product to use than regular 1", 2" or 3" tape for the following reasons:

- ⇒ Bias cut cloth does not unravel on the edges. It also does not have a selvage edge that will create a hard ridge when the epoxy cures. Therefore, you should be able to feather it into the hull shape more easily.
- ⇒ Since the strands of fiberglass run on an angle across the width of the tape, you end up with more strength with just one application. With regular tape the threads run at 90 degrees to each other, giving you strands that have strength running perpendicular to the length of the tape only; you lose the assistance of the threads that run along the length of the tape.
- ⇒ Cloth cut on a bias will wrap around severe corners without resistance; normal tape resists and will create bubbles as it pulls away from the surface.
- ⇒ Since the bias cut cloth is cut from the same cloth you are using for the hull, it will wet out better than the regular tape, which is 9 oz.



If there is a downside to this, it is that you will have to cut the cloth in 6' and shorter strips; you will not get a continuous strip of tape. On the other hand, this gives you shorter sections of tape that will be easier to work with especially when you are dealing with the taped seams on a kayak.

Again, refer to our Fiberglassing DVD for a demonstration of what you can do with Bias Tape.

If you don't understand this description or have questions, PLEASE call us or e-mail before you start. We welcome your questions.

the sander in a smooth motion back and forth parallel with the strips, keeping the sander in contact with the surface and moving at all times. If you have to stop, lift the sander up. Many sanders will accelerate when removed from the surface. If you bring them back down onto the surface when they are going fast you can create a divot. Instead, turn off the sander, put it back down and then restart. You don't need to wait for the sander to stop completely before using it, but let it slow somewhat. If the sander is still moving, bring it down while sweeping the surface so it does not dig into one spot.

A time saving step: When you can't see any more scratches and the surface is uniformly smooth, wet down the surface with water and let it dry overnight. This will raise the grain, highlight scratches, and show up any remaining glue. It will also swell the staple holes, reducing the possibility of epoxy seeping through during the clear coating. Remove the glue and remaining scratches with further sanding, then sand the whole boat again with 80 grit sandpaper. This sanding could be done by hand, with the grain. You do not need to sand any further than this. Finer sandpaper is unnecessary. The epoxy bonds best to a fairly coarse surface. As long as any scratches across the grain have been removed, further sanding will not improve the appearance of the boat. Excessive sanding with fine sandpaper on the Random Orbit Sander can cause dark red cedar to have a blotchy effect, since you are actually buffing the wood fibers.

You will have much less work on the inside of your hull if you can take the time to do the water wet-out step above. The water will swell the staple holes so that the epoxy won't seep through. This will eliminate hours of scraping off lines of epoxy on the inside hull later.

Keel (optional):

We are now supplying a keel with most of our canoe kits. The exceptions are the Voyager and Wee Lassie II as we feel that they track fine as is. The Otter should definitely have a keel as it is so short that it tends to zig-zag. The reason for installing a keel is to keep the canoe tracking better and minimize side drifting in the wind. A keel is good to have on lakes and larger bodies of water. You may not want a keel if you are using your canoe on a river frequently where you need more maneuverability to avoid rocks and other obstacles. A canoe without a keel can be enticed to track better by use of a J stroke by the stern paddler. However, it may get pushed sideways very easily when out on a lake or large, slow moving river.

Our keels are ash, about 3/4" wide at the base and cut to a trapezoidal shape, about 3/4-7/8" tall with a 1/2" flat spot on the outer surface. You can apply the keel to the full length of the canoe, overlapping the outer stems OR you could cut the keel shorter and apply it in the center of the canoe. Either way, you will need to taper the keel so that it blends into the hull or stems at both ends.

The best time to install the keel is **after the cloth coat of epoxy** while the canoe is still on the strongback. It could also be installed after one or more filler coats of epoxy are applied to the outer hull, but I definitely recommend installing the keel before taking the hull off the forms. Once the hull is off the forms you risk distorting it when you strap the keel down.

Find the center line of the canoe by laying the keel on it dry. Make some light marks as reference points so you know where you need to sand and where to apply thickened epoxy. Take a wood rasp and scuff up the base surface of the keel where it will contact the hull. You need to do this to create scratches and gouges that the epoxy can grip into. Take some 40 grit sandpaper and scuff up the hull where the keel will contact it.

If you are going to overlap the outer stem with the keel, then you will need to flatten the stem down to the hull in preparation (see pictures at right). This is how we did one canoe but you could simply blend both outer stems down to the hull and apply a shorter keel that would itself get tapered to the hull, your choice.

Get some ratchet straps. You will be using these to hold the keel in place overnight while the epoxy cures. You can get an inexpensive set at Wal-Mart or Home Depot. Another way to do this is to use a "Spanish Windlass", the poor man's clamp. This is simply a rope tied loosely around the hull with a stick used to twist it for tightening purposes. At any rate, get all your straps and/or ropes ready BEFORE mixing any epoxy.

When you are all ready, mix a small batch of epoxy, thicken with Cell-o-Fill or silica thickener. Put it in a plastic sandwich bag, cut one corner and squeeze the epoxy mix out onto the hull where the keel will attach. Strap the keel to the hull with ratchets and/or windlass starting in the center and working to the ends. Use some small wood wedges under the rope or strap to drive the keel down to the hull. Go from one end of the boat to the other and sight down the keel. Poke it one way or the other to get it straight. Note that even a keel piece that has a curve in it can be made to conform to the hull in a straight line. Note that we have pieces of cardboard under the ratchet hooks in order to keep them from damaging the fiberglass on the outer hull—this is important!



Use your gloved finger to spread the squeeze out of epoxy into a small fillet along both edges of the keel. Leave this over night. Next day, remove straps and ropes. If the fillets aren't continuous or they are lumpy, you will need to fix them before proceeding (scrape the lumps and fill the gaps with more thickened epoxy). Use a plane to taper the keel to the hull at both ends. Round over the top edges of the keel. Scuff up the hull for 4-5" or so on both sides of the keel and apply bias cut pieces of cloth from the hull on one side, up and over the keel to the hull on the other side.

The next day, scrape the edges of the bias cloth, scuff up the rest of the hull with 100 grit sandpaper by hand, and proceed with your filler coats. Now your goal is to blend the bias with filler coats so you can't see it.

If you are going to add graphite or barrier coat, the time to do it is after you have at least one filler coat of epoxy on the whole hull. If you try to tape an edge and apply graphite with epoxy right after the cloth coat, it can bleed under the tape and you won't get a good, crisp line.

Graphite/Barrier Coat:

The graphite is a fine powder that is mixed into the last two "filler" coats of epoxy on the bottom of the hull. Barrier coat is an aluminum powder, a West System product. Two coats are necessary because the first will leave a translucent result. You will need to sand between coats of graphite/epoxy and sand after the final coat. In the case of the graphite, this leaves a chalky, charcoal colored hull that looks like it is painted flat black. The barrier coat is a light, battleship gray. You do NOT varnish over the graphite or barrier mix, but will varnish over the rest of the hull. This requires that you mask off where you will be applying the graphite and later mask off the graphite to varnish the upper hull. You don't absolutely have to sand the last graphite or barrier coat; you could leave it glossy. We applied a barrier coat to a canoe with a roller and ended up with a stipple finish that looks like a light gray bed liner in a truck.

The downside to this is that sanding the graphite generates a lot of fine black dust that can infiltrate your varnish operation later. You will need to mask with a good tape, such as 3M Fine Line Vinyl Tape.

The benefit of this additive is that it will skim over rocks and obstacles rather than dig in as tends to happen with a varnished hull. You can have the benefit of protection along with maintaining the beauty of the boat.

Epoxy/Fiberglass:

Note: The following procedures are the methods we use for **MAS Epoxy or System Three Silvertip Marine Epoxy**.....if you are using another epoxy, refer to the manufacturer's instructions.



Apply sealer coat on hull:

If there are any major gaps or holes between the strips, apply tape on the inside of the hull to close the gap and prevent epoxy from dripping through. This will prevent premature staining and additional scraping later on when prepping the interior.

- ⊗ Get out your respirator with organic vapor filters, make sure it fits well, and use it when you are applying the epoxy. Also, wear safety glasses to protect your eyes from possible epoxy splashes.

Mix a small batch of epoxy and apply to the outer hull starting in the middle of the centerline working down to the sheerline and towards the bow and stern. Use a squeegee to spread the epoxy on the flatter surfaces and use a brush with short bristles to apply on the more vertical surfaces to avoid dripping and excessive waste. The goal here is a thin sealer coat to facilitate fiberglassing in the next step. The epoxy will be absorbed into the wood and there should not be any “shiny” thicker spots of epoxy. Use a squeegee to remove excess epoxy, and a short bristle paint roller on the entire hull to even out the coat.

Now is the time to fill the gaps and holes, immediately after applying the sealer coat, using thickened epoxy. You can use any leftover epoxy from the sealer coat or mix a new batch. Mix in Cab-o-sil until you achieve the consistency of peanut butter and add wood flour to bring the mixture to a color that will blend with the strips you are using. Work the epoxy into the gaps with a stick or squeegee, keeping it flush with the surface.

- ⊗ It will help to view our [Fiberglassing DVD](#) before proceeding.

Fiberglass the outer hull:

Gently scrape the areas where you applied epoxy to gaps or holes to blend them smoothly into the surrounding surface. Try not to scrape through the sealer coat into the wood. Keep in mind that with **System Three SilverTip Marine Epoxy**, you don't have to be concerned about amine blush. If you can apply the cloth coat after the sealer coat has just become tack free then you don't have to sand as the new epoxy will chemically bond to the “green” sealer coat epoxy. If you need to wait longer than 6 hours, say overnight, then you should hand sand the sealer coat before proceeding. Be careful to avoid sanding through the epoxy and into the wood as it will cause discoloration later. Clean the hull with a vacuum, watching for any problem areas you might have missed. If some of the gaps need additional filling, you can add more thickened epoxy just prior to laying on the cloth.



A scraper easily removes lumps and drools in the green stage of curing

It is NOT necessary to clean with acetone or lacquer thinner. We avoid using these highly toxic chemicals. **Don't use a tack cloth!** This will just introduce more unwanted chemicals into the equation. WHITE VINEGAR can be used to clean your tools. However, vinegar **SHOULD NOT** be used to clean your hands, nor should any solvent such as acetone; these will only speed the entry of the epoxy into your body. Instead use a hand cleaner such as "Fast Orange" or "SBS-30" waterless hand cleaner (supplied with our application supplies). The best protection is to wear gloves and avoid getting any resin on your skin.

- ⊗ Use your respirator with organic vapor filters when you are applying the epoxy. Also, wear safety glasses to protect your eyes from possible epoxy splashes.

Lay the fiberglass cloth lengthwise over the hull, letting it extend 2" beyond each stem and trim it to within 2" of the sheer line using shears. Leaving the cloth draped over the hull overnight seems to help it to lie flat and eliminate wrinkles, but this isn't absolutely necessary. You can easily remove wrinkles by gently brushing with one of the 2" china bristle brushes (dry of course).

Get all of your tools ready: Tyvek sleeves, vinyl gloves, mixing sticks, brushes, squeegees, plastic containers. It may help to lay everything out on a piece of cardboard and place cardboard or kraft paper beneath the canoe; as you go along, you will inadvertently drool epoxy.

- ⊗ Mix resin/catalyst in 2 to 1 ratio; with calibrated pumps this means equal full pumps of resin to catalyst. If the pumps spurt air the ratio may suffer; we supply calibrated plastic cups so that you can double check your ratio as you go. Since the calibrations are on the inside of the cup, you might want to mark some significant lines in indelible marker on the outside of the container before starting. When the epoxy covers the inside lines, they tend to become very difficult to see.

MIX YOUR RESIN/HARDENER MIXTURE THOROUGHLY. We usually only mix 6 oz. of epoxy at a time to prevent premature cure and to allow us time to spread it into the cloth. Originally, we just poured the epoxy mix onto the "football" and spread it into the cloth with the squeegees. On occasion, we found that where the epoxy got ahead of us and drooled down toward the sheer line it could leave drool marks in the cedar. Therefore, our most effective method of application seems to be to brush the epoxy onto the cloth with the 2" brush supplied; this works particularly well on the steep sides of the canoe heading down to the sheer line. A roller can be used on the cloth coat to help spread the epoxy more evenly, but we prefer to use a brush to spread the epoxy onto the cloth for wet out and then use the yellow plastic piece to squeegee off the excess.

- ⊗ MIX YOUR RESIN/HARDENER THOROUGHLY IN A SMALL CONTAINER. A large, flat container will NOT allow the resin and catalyst to combine completely.

As the cloth becomes saturated with the epoxy, it will become fairly clear and you can begin spreading with the squeegee, sending excess epoxy onto virgin areas of cloth. ALWAYS work from the top of the football area (on the outside of the canoe) down to the sheer lines, THEN out toward the stems. On the inside, we usually start in the football area and work UP toward the sheer lines and out toward the stems. If you have two people working, be careful not to jump ahead, as the cloth can wrinkle up. Don't panic, you have about 45 minutes at 70 degrees before epoxy IN A THIN FILM mixed with slow catalyst starts to cure. Epoxy left concentrated in the mixing container will start to thicken in about 15 minutes (slow hardener alone).

As you squeegee, try not to bear down heavily as it is possible to actually pull epoxy out of the cloth and create a starved area. Ideally you want the cloth to be saturated with an equal film of epoxy in all areas. We have found MAS epoxy to be somewhat self-leveling so that we don't usually have to fuss too much with it after the squeegee process.

When you get to the stems and the cloth is saturated as far as you can go, cut the little tent off that formed when you draped the cloth over the hull. You have probably found that the cloth wants to bubble up and not stick to the stem area where it blends into the hull on the bottom. Take a pair of scissors and cut the cloth right down the stem. Use your scissors to cut the cloth to within 1/2" of the stems and the sheer line. If you don't do this, the tumblehome curve on some designs will pull the cloth away from the sheer and no amount of pushing and prodding will get it to stick. After 5 to 8 hours of cure time, the 1/2" excess cloth (saturated by epoxy) can be trimmed off easily with the utility knife. Since the cloth ties the strips to the outside stem on the sides, we don't worry about overlapping the cloth over the END of the stems... ..just trim off the excess as with the sheer.

WHEN APPLYING CLOTH COATS OF EPOXY LEAVE YOURSELF A WINDOW OF TIME SO THAT YOU CAN STAY WITH THE PROJECT IN CASE THE CLOTH BUBBLES FROM ESCAPING AIR. This usually only happens when you apply the epoxy during a period of rising temperature.

- ⊗ Therefore, it is wise to apply your cloth coats (outside and inside) in the late afternoon so that the temperature will be decreasing during the initial cure stage.

After the cloth coat has cured for about five to six hours, it should be barely tacky. It can be recoated without further preparation AT THIS TIME. After 6-8 hours, a light sanding is necessary to create a mechanical bond between layers of epoxy. It takes three to five days for this epoxy to achieve final cure... ..serious sanding should wait for full cure. These times vary due to temperature. **The rule of thumb is if you can make a mark in the epoxy with your thumb-nail, you don't need to sand.** On cool days epoxy may take more than 6 hours to cure to the point where it is no longer tacky. If you are in a rush, it may be worthwhile adding some fast catalyst to the mix; slow and fast can be combined as long as the ratio of resin to hardener is ALWAYS two to one.

For the filler coats you don't need to worry about the temperature rising as the hull is all completely sealed with epoxy at this point.

Amine blush is a waxy by-product of the curing process with some epoxies. It is most likely to occur on humid days. The hardened epoxy will feel slightly tacky or slimy and it will gum up sandpaper. It must be washed off with water before another coat will properly adhere. If you are unsure, it does not hurt to wash the boat off anyway. With **SYSTEM THREE SILVERTIP EPOXY or MAS EPOXY**, amine blush is NOT created when Slow Hardener is used OR if Fast Catalyst is used in a combined mix.

At this time you may want to apply bias cut strips of cloth to the stem areas, just prior to the fill coats.

This is when you may want to install the keel if you are going to do it. Refer to Keel Installation instructions above.

Additional coats of epoxy can be applied most effectively by pouring onto the football area, spreading as much as possible with the squeegee, rolling with the epoxy application rollers, or brushing with a 2" disposable brush. If you cut a 9" roller to 4", you won't need any more than two 9" rollers. We have found that the roller carries a fair amount of epoxy around without creating bubbles once it has been saturated with epoxy. Use the roller somewhat gently as vigorous action on your part can create milky white epoxy which is an indication of fine bubbles pumped into the mix. If you use foam rollers, bubbles MUST be tipped out with a brush before they freeze in with the cure.

⊗ We usually apply the first filler coat with a 2" brush. Remember, at this point you are trying to get a lot of epoxy to fill the weave of the cloth as evenly as possible. Rolling these coats on will give you thinner coats and you may have to apply more coats to fill the weave.

The object at this point is to get enough epoxy onto the cloth so the weave is filled and you won't be sanding into the cloth when you sand the epoxy. Usually two coats of epoxy after the cloth coat will be enough. The avoidance of drools, lumps, etc. in the epoxy will save considerable sanding time later.

After all epoxy coats are applied to the outside, wait two to three days for initial cure to stiffen the hull, then sand the hull while it is still captured on the forms.

⊗ If you have lumps and drools, use a scraper to take these off while the epoxy is in the green cure stage (within 8-10 hours). Sanding drools with out scraping first may cause you to end up with a wavy hull.

If you have time, it is nice to get a coat or two of varnish on the hull before removing it from the forms (if you are building a canoe or rowing boat). Sand the epoxy with a random orbit sander using an Interface Pad (we have them to fit a 5 hole OR 8 hole, 5 " sanders with hook and loop) and 80 grit sandpaper, down to 220 grit (see Finishing section on page 16). Be sure to tape off the area where the gunwales will be epoxied to the hull, otherwise you will need to remove the varnish later for proper adhesion.

Remove the hull from the form by unscrewing the stem forms and carefully sliding the hull up and over the other forms.

You can mark the inside of the hull with the sheerline points before taking the hull off the forms. A cardboard template can be made to mark the sheer line up to the stems. This can be cut with a saber saw before applying cloth and epoxy to the inside. Or you can use a strip as a 'batten' to create a fair, pleasing curve. Mark it on one side/end of the canoe and cut it, then take the cut off piece and use it as a template to mark the other side on that end and both of the other ends of the canoe. See picture at right.



Use an extra strip to mark the sheerline before cutting with a saber or pull saw

The inside cloth coat goes much the same way, right down to draping the cloth over the OUTSIDE of the hull and trimming to the stem profiles with scissors. This will save some panicky moments as you try to get rid of excess cloth in the inside of the stems while the epoxy starts to cure.

You may want to apply some cloth cut on a bias over the inner stems when you apply the sealer coat to the inner hull. **If you do, use the cloth left over from what you applied to the outer hull so you don't short yourself on the inside of the boat.** See the DVD for a good demonstration of this.

We usually apply only the cloth coat of epoxy to the inside... ..this leaves a matte finish with good traction properties and avoids having to sand epoxy on the inside of the canoe. If you have excess epoxy you can squeegee it out. This will give you a tight cloth coat that can be left for traction. Try to avoid pushing the cloth around, this will only cause wrinkles or ripples.

A solo canoe should not need more than 1 ½ gallons of epoxy, a tandem canoe will need 2-1/4 gallons of epoxy, however you might find you are going through it fast. This could be because you are wasting it by mixing too much or you are laying it on too thick. Make sure before doing each coat that you will have enough to get through the whole coat. You do not want to have half the layer of fiberglass wet-out only to find you have run out of resin. It will be difficult to get a smooth transition if you have to let the epoxy cure before finishing the wet-out. Your best bet if this does happen is to cut off the excess fiberglass so that all the fiberglass on the boat is fully wet out. Come back later with fresh fiberglass and overlap the joint by a couple inches. If you anticipate more coats of epoxy than described here, you will need more material than the epoxy package supplied with your kit.

If you are concerned about the fiberglassing process:

Cut off a corner of the fiberglass cloth about 16" x 16"... ..you'll see when you drape the cloth over the hull that you won't need this anyway. Mix a small batch of epoxy/catalyst (one squirt each) and apply the cloth to a piece of scrap wood. This will give you a feel for the consistency, how the cloth wets out, what the working time is, and what is involved in the process without risking the hull.

Using Epoxy in Extreme Temperatures:

It has come to our attention recently some of our customers have experienced air bubbles under the epoxy when applying the cloth coat to the interior of the canoe or kayak. This phenomenon is called "outgassing" and is caused by air trapped in the cedar or between the strip joints trying to escape. It most frequently occurs during a period of rising temperature, but can occur with less intensity during a period of falling temperature.

Remedies for this situation are as follows:

- 1) When applying the cloth coat to the outside or inside of the canoe/kayak, do it during a period of falling temperatures. That is, start late in the afternoon or early evening when the hull temperatures are as warm as

they will be for that day. Then as the epoxy is curing, the hull and ambient temperatures are falling as you proceed into the evening.

- 2) Leave yourself a window of time so you can stick with the project or return frequently to see if any bubbling has occurred. If it has, you can usually get the cloth to stick to the hull by pressing gently on the bubble with a spreader. Usually, the air will escape on its own when the epoxy is fresh; when the epoxy thickens and starts to cure, it traps the air.
- 3) Apply the sealer coat the day before you do the cloth coat. This will help seal off the air or will tend to fill in the minor gaps that produce the air.
- 4) Use the spreader to gently squeegee the excess epoxy off, keeping the squeegee at a low angle. If you use too much intensity, you will starve the cloth.

System Three SilverTip Marine Epoxy AND MAS Epoxy are designed to be mixed at 75 degrees. If the conditions in your work space are cooler than this or the resin and hardener are kept in a cool place, you would benefit by pre-heating the epoxy to lower the viscosity, thereby facilitating proper mixing and wetting out the cloth. There are many ways to warm up the epoxy, including a hot water bath, a heating pad, or simply keeping the containers in a warm room. Higher temperatures won't necessarily speed up the "cook-off" time of the mix as it will quickly come to room temperature when you apply it to the surface.

Another possible problem that needs to be addressed is that of cloth ripples. If you use the bristle rollers we provide to help level the epoxy, you could cause ripples to be left in the cloth. These ripples are there because you may have been rolling kitty-corner across the beam and as the cloth absorbs epoxy, it will stretch and conform to the shape of the boat or go any where you push or pull. The solution to this situation is to roll or squeegee (gently) ONE WAY, from the center of the boat toward the stems if you can or across the beam of the boat. This should adjust the cloth longitudinally and the ripples will disappear. **This has to be done before the epoxy thickens or the ripples will be frozen there forever.**

We know the above procedures work well with **SYSTEM THREE SILVERTIP EPOXY and MAS EPOXY**. We are trying to communicate the easiest method for a first-time boat builder to achieve quality results.

If you use another epoxy, consult the manufacturer for their recommendations.

Gunwales & Decks:

Our kits are based on the decks nesting flush with the sheer and the inwales installed UP TO THE INNER STEM. We provide the decks as three 1/4" pieces (for designs such as the Traveler, White Guide, Kruger, & Abenaki) that can be bent and laminated with epoxy thickened with Cab-o-sil to match the upward curve of the sheerline. For other designs, such as the Voyager, Otter, Wee Lassie and Wee Lassie II, we provide one piece decks as the upward sweep of the sheerline doesn't require a curved deck.

- ⊗ If you have inwales with scuppers, NOTE: Before you install your inwales, you may want to round over the edges of the scuppers slightly and coat them using an acid brush and clear, unthickened epoxy. This could be done at the end of one of your fiberglass coating sessions. Usually it takes two coats of epoxy to give the scuppers a good coat.



Before you attempt to install your gunwales, your sheerline has to be FAIR. Some designs have a dramatic re-curve, or rising of the sheerline at the stems, and the hull needs to be trimmed to the sheerline. Using an extra strip, begin clamping it to the hull near the middle and work towards the stems, bending and clamping the strip

as you proceed to achieve a smooth, fair curve. Adjust the curve as necessary then mark along the edge of the strip with a knife or pencil. Using a pull saw or saber saw, cut to the line. Try to cut the extra strips cleanly so you can use the cut-off as a template for the sheerline on the opposite side, and the other end if it is a symmetrical design.

On designs that don't need to be trimmed, you can spoke shave the cove edge of the sheer strip down to the bottom of the cove (carefully) and then use the fairing board to blend the sheerline.

When you look at your inwales you will find a center line marked on the inside of the 5" section. This should be lined up as closely as possible with the center staple holes from the "0" station. Clamp the inwales to the inner hull, mark where they touch the inner stem and cut them. We have found that you can cut the inwales about 1/4" short of the inner stem, then tape them together, clamp to a table, and taper the INNER sides with a hand plane from near the last scupper to the ends. This will give you a flat edge to mount the decks into. If you're careful, you can get the end of the inwale to a fine feathered end that will look like it fades into the hull when attached.

Before installing the inwales and outwales, make sure to rough up the inside, gluing surfaces with a wood rasp to create grooves for the epoxy to "bite" into. Also rough up the epoxy on the edge of the sheerline with 60 grit sandpaper for the same reason.

To install the inwales, you can use a lot of clamps or you can use 3/4" x #8 washer head screws THROUGH the cedar into the inwales... ..it helps to clamp and pre-drill the screw holes. **Make sure you wax the screws so you can remove them after the epoxy cures** (If you want these screws, we can supply them or you can order from McFeeley's). Mix a batch of epoxy with Cab-o-sil, apply to the inside of the inwale, and screw or clamp along the sheer line. The gunwales should end up about 1/32" below the cedar at the sheer line so you can spokeshave the cedar flush when the epoxy cures. This will give you a smooth, continuous edge to line up the outwales.

If you use clamps instead of screws to hold your gunwales, be careful the gunwales do not slide in the thickened epoxy.

Our decks for a canoe with recurved stems come to you as three thin pieces that will be clamped to the sheerline as shown in the picture and epoxied to each other before the gunwales are installed as shown in the picture at right.

After the inwales are installed, the deck material is laid over the stem area, pencil marked from beneath, and cut to fit. BE CAREFUL!!!! It pays to cut slightly oversize and plane or sand to the final fit. Depending on the canoe design, you may have to slightly angle the edges of the deck for a good fit. We have found it is visually appealing to cut a radius in the deck from inwale to inwale.

It may pay to clear coat the undersides of the decks with epoxy before installation, as this area is difficult to get to later. Install the decks using the same 3/4" screws and epoxy as with the inwales.

The outwales need to be tapered the last 30" to the stems, similar to the method used for the inwales, but this time you must taper the INSIDE of the outwale... ..do not taper the outside of the outwale, as you will be removing the shaped edge.

Outwales can be installed with clamps (you'll need a lot) or they can be installed with 1-1/4" x #8 screws and epoxy. These screws penetrate from the outside, through the cedar and into the inwales. You can pre-drill countersunk holes in the outwales



This shows the deck being glued to match the curve of the sheerline. When cured it will be cut to fit inside the inwales. This glue up can be done when the sheerline is cut (as shown here) OR later after the inwales are installed.

using a #8 Fuller Bit. It drills a pilot hole for a screw and then creates a large opening to “countersink” the heads of the screws. Then clamp the outwale to the hull and dry-fit a half dozen screws so you know what your plan of attack will be. If you use cabinet face-frame screws, you shouldn’t have to drill through the hull and into the inwale; the screw is self tapping. We have been waxing these screws and removing them when the epoxy is cured. Then just plug the screw holes with 3/8” contrasting wood plugs. An option here would be to just chamfer the holes in the outwales, use the waxed steel screws as above, and then replace them with silicone bronze wood screws that will show on the outwale. If you wish to use this method, we can supply 1-1/2” silicone bronze screws.

Seats and Thwarts:

Refer to the detailed instructions in *The Illustrated Guide to Wood Strip Canoe Building* or *Canoecraft* for placement of your seats and thwarts. Be sure to mount them between the scuppers in the inwales if you are using bolts in the traditional manner.

Seat Bolts are available in silicone bronze or stainless steel and 4” to 6” long. These are mounted in a hole down through the gunwales, through the ash seat hangers and through holes in the crosspieces of the seats. The stainless steel bolts can either be countersunk into the gunwales or set into finish washers on the top of the gunwale. With the bronze carriage bolts, the square section of the bolt directly under the head should set into the gunwale.

When locating your seat heights you want the seat high enough you can get your feet under it, but otherwise low to keep your center of gravity low for better stability.

You can also attach the seats to cleats glued to the hull. If you got a kit, this is what is supplied. The cleats are made of solid wood, usually Spanish cedar, approximately 12” x 2” x 1” shaped with a block plane or rasp to fit flush against the hull at the proper height for your seat. Level the hull as best as you can in the slings or supports, then level each cleat, or you may want to dip the cleats forward slightly. Temporarily tape the cleats to the hull then use two pieces of scrap wood to simulate the seat and place them across the cleats to ensure they sit flush and trim the cleats if necessary. Use a pencil to mark the hull where the cleats are positioned and remove the cleats. Rough up the fiberglass where the cleats are and rough up the glue surface of the cleat, then use thickened epoxy to attach the cleats. If the epoxy is thick enough they should not slide out of place but use duct tape and/or clamp just in case. Later use thickened epoxy to make a fillet all around the cleat where it meets the hull and then apply bias cut fiberglass over the cleat and on to the hull at least 2” above and below. Don’t worry about covering the ends of the cleats with cloth, just clear coat with epoxy. Scrape the edges of the cloth while it’s still green to blend in to the hull fiberglass. This edge will disappear later when you varnish with matte finish HMG varnish. The seats are attached to the cleats after all the varnishing is done with wood screws countersunk in the seat or with silicon bronze carriage bolts through seat rail and cleat. Note that some canoes have lots of tumblehome so you will need to use wood screws as you won’t be able to drill the holes through rail and cleat. Dip the screws in varnish before screwing them in to help seal the wood.

Thwart bolts are just like seat bolts but are 2” long, either stainless steel or silicon bronze. We install one or two bolts at each end of the thwart.

Finishing:

The outside epoxy should be sanded with 80 then 180 grit on a random orbit sander. Be careful not to sand into the cloth; you will be able to see the low spots as they will remain glossy. If you have a lot of low spots or "craters" and you can see the weave of the cloth in places as you're sanding, you may need to apply a brushed-on or rolled-on coat of epoxy to help fill the low spots. We would apply this coat to the whole exterior hull after rough sanding to get rid of extreme defects. If there are just a few areas, you can apply epoxy only in those areas and gently scrape the edges to feather into the adjacent area. Complete the sanding with the random orbit

sander to 220 grit or you can wet sand with even finer grit. Wipe the hull with a lint-free cloth dampened with the varnish-appropriate thinner.

Don't expect to get a fine finish when applying the epoxy. The last epoxy coat will ALWAYS have to be sanded to eliminate dust balls, drips, drools and surface inconsistencies. When is it the last coat you ask? Well, like a lot of areas in boatbuilding (and life) there is a large dollop of judgment in this. For example, if you are sanding the outer hull after the sealer coat, cloth coat and two filler coats you might think that you can sand nice and smooth for the final varnish finish. Wrong. You will be sanding along and see that you are starting to sand into the weave of the cloth in some areas while in other areas you will see little glossy dimples, an indication of low spots. My solution here is to sand the hull overall to remove the gloss without concentrating in any one area (with 80 grit, no finer), and then apply another coat of epoxy to sort of "level" out these variations. If you have used bias cloth wrapped around the stems or transom of a rowing boat you may have to apply a couple of leveling coats. You will have variations on your hull from the 'drop' at the edge of the bias and the sheering action of the epoxy sliding down the vertical sections. Whether or not to apply this "leveling coat" is a judgment call on your part. Our method at this point is to apply this coat with a brush and then gently roll it with a bristle application roller (a foam roller will work, but you have to be careful not to be too vigorous as you will introduce foamy white bubbles into the equation. These bubbles aren't much of a problem with MAS or System Three SilverTip Epoxy, but can freeze into the hull with a fast curing epoxy). My theory here is that if you can use a faster cure version of the epoxy system you started out with (Medium MAS or Fast SilverTip), the epoxy will set up quickly enough so that there will be fewer drips and drools on the vertical surfaces.

This leveling coat will be much easier to apply, kind of like thick varnish, because you don't have all the coarseness of the cloth pulling at your brush and sucking the epoxy right out of it.

Anyway, even the last, most perfect coat of epoxy **won't be like a varnish coat**. I don't think there is much you can do about all the little 'dust picks' that land on the surface. System Three tells us that once you apply a coat like this you could use a propane burner to "warm the surface" of the epoxy to induce it to flow out better and eliminate bubbles. Be very careful here: too 'warm' and you will have some major problems. You need to sand the epoxy with 80 grit to get through the gloss and remove dust balls, then with 120, 180, and finally 220. These latter grits are meant to eliminate the scratches from the 80 grit. Even so, after the first coat of varnish you may see scratch swirls in the reflection. This is normal. Wet sand the varnish with 220-240 grit and the next varnish coat should fill these scratches.

Epoxy MUST be coated with a Spar Varnish or Urethane with UV inhibitors to prevent deterioration from sunlight. Traditional varnishes such as Epifanes or Coma Berenice will give you a high gloss finish. Thin this varnish when applying the first coat on raw wood parts, such as the cut ends of seat frames. Then follow up with at least three coats of varnish (thinned by 5%), wet sanding with 220 or 320 grit between coats. When you are varnishing epoxy, thin only to maintain correct flow out of the varnish you are using.

An option here would be to clear-coat all of the wood parts with epoxy (we do this on all of our boats). This usually takes two coats with sanding in between. The advantage of this is that you will create an epoxy barrier coat on the wood parts that will fill the grain of the wood on species such as ash, eliminating several coats of built-up varnish. Then varnish the wood parts at the same time and in the same manner as the hull.

The exception to the above process is the canoe seats. Since the natural cane is already installed, we normally just coat everything with two or three coats of varnish, even the cane.

On the epoxy coated hull, you can varnish and thin only enough to get good flow out. How much thinning is necessary will depend on your brand of varnish and the viscosity. This varnish will need 24 hours to dry between coats before you can sand. We have Coma Berenice Spar Varnish in gloss we use for the decks, gunwales, and outer hull and HMG Marine Varnish in matte finish that works well for the interior of a canoe or rowing boat, especially if you have left the "matt" cloth finish on the inside.

SEE OUR INFORMATION AT THE END OF THESE NOTES ON USING HMG VARNISH.

We have had the best success applying the varnish with a China bristle brush. Apply the varnish evenly using vertical strokes to a 12 -18" long section on one side of the boat. Then smooth the finish with horizontal brush strokes. Switch sides and repeat the process, overlapping in the middle. Switch back over and repeat on the first side, with a couple inches of overlap. Keep this up until the boat is covered, always working with wet edges. As you move down the boat look back at the section you just did to make sure you didn't miss a spot. If you did, you can touch it up. You do not want to have touch up spots two or three sections back because the brush marks will show as the varnish has already begun to set up.



Although you don't want any drools in earlier coats, only the final coat needs to be "perfect". You should sand between coats with fine sandpaper and this will remove most imperfections. Wet sanding with a 220 grit paper or scuffing with Scotch brite will produce the best results. If you have runs or drools it will help to use a sharp scraper on them before wet sanding.



Tie-Off Loops, Rings, and Shoulder-Bolts:

We can provide brass pad eyes for tie offs. You could also put a brass ring through the pad eye, but it will clank and make noise as you paddle, so we recommend using a loop of rope through the pad eye.



Shoulder-bolts or eye-bolts are mounted by drilling completely through the stem-band, outer and inner stem. File a small flat spot on the stem band. Very carefully drill a hole through the stem band being sure to keep the drill centered. Keep drilling straight into the stems, keep making sure the drill is going straight. Push the eye-bolt through the hole and put the nut and washer on the inside.

Enjoy!



Varnishing Your Cedar Strip/Epoxy Boat With HMG Varnish



You need several conditions to be successful in this process:

- Good Surface Preparation
- Good lighting
- User friendly varnish
- Clean, dust free environment
- Patience

Surface Preparation:

The epoxied surface should be sanded to 220 grit.

- Use a random orbit sander for the large areas; sand by hand on sharp corners and curves to minimize sanding through the epoxy into the cloth.

Vacuum when done dry sanding, wash the surface with water and 10% ammonia.

You need several conditions to be successful in this process:

- Good Surface Preparation
- Good lighting
- User friendly varnish
- Clean, dust free environment
- Patience

Surface Preparation:

The epoxied surface should be sanded to 220 grit.

- Use a random orbit sander for the large areas; sand by hand on sharp corners and curves to minimize sanding through the epoxy into the cloth.

- Vacuum when done dry sanding, wash the surface with water and 10% ammonia. Hand water-sand with 240-320 grit wet sandpaper.
- Thoroughly clean the surface with ammonia/water and allow to dry.
- Create your own tack rag using a lint-free cloth with a little HMG Reducer to dampen it. Wipe the whole sanded surface carefully with the rag.

Between Coats:

After each coat is dry, wet sand with 240 grit wet/dry sandpaper. Clean up the sanding slurry with a clean sponge, water and 10% ammonia. Take care of drips, drools, and sags by scraping them before wet sanding. Another option is to scuff the varnish with Scotch Brite. We prefer this to sanding as it doesn't remove as much of the varnish. You want to 'build' the thickness of the varnish.

Area Preparation:

It helps if you can varnish your boat in an area that hasn't been exposed to hours of cedar and epoxy sanding. However, this probably isn't the case, so

- After the final dry sanding, vacuum and clean your work area thoroughly a day or two before you intend to varnish.
- When you then start to varnish, try to resist stirring the air up if you can help it.
- Wear fresh, clean clothes to varnish. Or better yet, a new Tyvek suit. Don't wear your old sweatshirt that you wore when sanding because you will reintroduce the dust right back into the area.
- If you can do it, the ultimate dust elimination solution is to wet the area down the day before varnishing. This assumes you are on a concrete floor with some sort of drainage.

Lighting:

Besides using good overhead lighting it works well to use more lights mounted down low, maybe at 3' from the floor. This allows you to see better in the reflections. One inexpensive type of lighting is clamp lights. These cost about \$6 each and can be clamped in various strategic places and then moved easily.

Varnish:

The Newfound Woodworks now supplies **HMG Coma Berenice Gloss Varnish**, and **Matt Finish K-type Varnish** with all of our kits. **Satin Finish K-Type Varnish** is an option. If you intend to apply Satin finish to the exterior hull you should apply gloss first as it has more UV inhibitors

The **Gloss varnish** is intended for the outer hull, decks, and gunwales, but should also be applied to the inner hull (2 coats) for better UV protection before applying Matte finish. It should be stirred thoroughly. Clean excess varnish out of the rim each time you use it, make sure the lid is on tightly, and you will minimize waste from skimmed over varnish.

- If you are varnishing raw wood, you should thin the first coat by about 15% with mineral spirits or ideally with HMG Reducer (thinner). Subsequent coats should be thinned by about 5%. The amount of thinning is determined by the ambient temperature and flow out conditions.
- Ideally, you would mix the varnish thoroughly and then pour into a separate container that you would use to varnish the boat. This will minimize dust and foreign debris from getting into the varnish can and contaminating it.
- When brushing varnish over an epoxy surface, thin the varnish about 5% unless the can has been opened several times and the solvents have evaporated somewhat leaving the viscosity of the varnish higher than normal. Then only thin to bring the varnish back to the 5% thinned viscosity.
- Spraying this varnish requires thinning to the degree that allows the varnish to flow through your type of spray equipment and atomize sufficiently. In this case, ALWAYS use HMG Reducer as it is compatible with this varnish. Use a viscosity cup to determine the exact viscosity or you can be very frustrated with the results.

The **Matt finish** is intended for the interior of your boat. Since the Matt eliminates reflections the interior will look better than it may actually be. Always stir the Matt thoroughly because the flattening agent will settle to the bottom of the can (and keep stirring as you work).

Technique:

You can brush this varnish using a foam brush, badger bristle brush, or a foam roller.

- The foam brush should be the tight foam type, not the kind with large holes. A 3” -4” brush will work fine.
- The foam roller needs to be followed up with a ‘tip out’ by a foam brush or a china bristle brush.
- The china bristle or “Badger” brush will give a better ‘feel’ as you are varnishing; this is our preference.

Canoe or Rowing boat:

- Start at one end and brush on the varnish first horizontally, then vertically in an area about 16-18” wide from the sheer line (gunwale) to the center bottom of the hull.
- Create an imaginary line at the bottom of the boat where you try not to go over. When you get to the other side you will brush up to this line and blend.
- Proceed from one 16” section to the next, overlapping your strokes to the last section. If conditions permit and the varnish is not drying too rapidly, try to switch sides of the hull as you progress so you can maintain a “wet” edge at both the line on the bottom and sides of each section. You can eliminate potential brush marks by adding fresh varnish to the edge of a previous section if it is still “wet.”
- Try to watch in the light reflection where you have been so you can correct misses and drips. You should only attempt to correct in the previous section. Once you have gone 3-4 sections an attempt at correcting a drip can end up with more of a problem.
- The purpose here is to get as much varnish on without getting drips and drools. Don’t worry too much about brush marks, they will flow out in about an hour. HMG varnishes are very forgiving once you thin slightly. The flow out rate is determined by how thin the varnish is and the ambient temps.
- Concentrate on applying the varnish in a smooth, consistent finish without missing anything but also without having excess in any one place. A drip or drool will occur when you have too much varnish on a vertical section.
- You will be amazed at how good a job you can do if you have patience and develop a consistent technique.

Kayak:

The hull of the kayak can be done as described for the canoe hull above, except

- Get some 3M Blue Quick Release Masking tape and tape off a line at the sheer line or some line parallel below it. This will give you a nice crisp line to varnish to. Without the tape you would be slopping here, there and everywhere and the overlaps at the sheerline when you varnish the deck will be obvious.
- As soon as you have the hull varnished, pull the blue tape off carefully. This will cause less of an edge because the wet varnish will flow minutely over the line.
- The next day, turn the boat over, tape the hull side of the line, and varnish the deck up to the line. Pull the blue tape when finished, before the varnish is dry.
- Flip over the next day and hand wetsand the hull using 240-320 grit wet sandpaper. Re-varnish as above.
- Flip over and do the wetsand/varnish on the deck. Continue this until you have 4 coats of varnish.

Brushing Matt Finish:

Matt finish varnish is much more forgiving than gloss. It will go on as a gloss and as it dries it seems to tighten up to the point that what might have been a drip or sag just disappears.

- If you are brushing Matt over the inner fiberglass layer you can prep the surface by rubbing it down with 3M Scotchbrite. Then vacuum thoroughly and tack rag the surface before varnishing.
- Sanding the rough fiberglass surface of the inside will only reduce the texture of the fiberglass that you are trying to maintain for traction.
- Use Scotchbrite lightly between coats also.

Some other thoughts:

- The Coma Berenice Varnish is slow drying. We think this is beneficial because it flows out and allows brush strokes to disappear. You may have to wait two days to sand between coats, especially if it is humid or the temperature is low.
- When you are sanding between coats, you are trying to scuff the gloss up a little and take care of any dust, drips and drools. The end purpose is to BUILD coats of varnish. You won't do this if you sand off everything you have just put on.
- We think that it is beneficial to clear coat the gunwales, decks, and any bare/raw wood with two coats of MAS Epoxy. This creates a final moisture barrier and lasts much longer than just varnish on raw wood. We don't normally epoxy coat the canoe seats, but DO varnish the natural cane along with the ash frame.
- Don't dispose of tack rags in your trash container until the solvent has evaporated from them. Piles of tack rags can spontaneously ignite and ruin a fun project.

Finally, the last coat is the one that really counts. Everything up to that is just building UV protection and practicing your varnishing technique!

